

1 Classification of Heat Exchangers

A variety of heat exchangers are used in industry and in their products. The objective of this chapter is to describe most of these heat exchangers in some detail using classification schemes. Starting with a definition, heat exchangers are classified according to transfer processes, number of fluids, degree of surface compactness, construction features, flow arrangements, and heat transfer mechanisms. With a detailed classification in each category, the terminology associated with a variety of these exchangers is introduced and practical applications are outlined. A brief mention is also made of the differences in design procedure for the various types of heat exchangers.

1.1 INTRODUCTION

A *heat exchanger* is a device that is used to transfer thermal energy (enthalpy) between two or more fluids, between a solid surface and a fluid, or between solid particulates and a fluid, at different temperatures and in thermal contact. In heat exchangers, there are usually no external heat and work interactions. Typical applications involve heating or cooling of a fluid stream of concern and evaporation or condensation of single- or multicomponent fluid streams. In other applications, the objective may be to recover or reject heat, or sterilize, pasteurize, fractionate, distill, concentrate, crystallize, or control a process fluid. In a few heat exchangers, the fluids exchanging heat are in direct contact. In most heat exchangers, heat transfer between fluids takes place through a separating wall or into and out of a wall in a transient manner. In many heat exchangers, the fluids are separated by a heat transfer surface, and ideally they do not mix or leak. Such exchangers are referred to as *direct transfer type*, or simply *recuperators*. In contrast, exchangers in which there is intermittent heat exchange between the hot and cold fluids—via thermal energy storage and release through the exchanger surface or matrix—are referred to as *indirect transfer type*, or simply *regenerators*. Such exchangers usually have fluid leakage from one fluid stream to the other, due to pressure differences and matrix rotation/valve switching. Common examples of heat exchangers are shell-and-tube exchangers, automobile radiators, condensers, evaporators, air preheaters, and cooling towers. If no phase change occurs in any of the fluids in the exchanger, it is sometimes referred to as a *sensible heat exchanger*. There could be internal thermal energy sources in the exchangers, such as in electric heaters and nuclear fuel elements. Combustion and chemical reaction may take place within the exchanger, such as in boilers, fired heaters, and fluidized-bed exchangers. Mechanical devices may be used in some exchangers such as in scraped surface exchangers, agitated vessels, and stirred tank reactors. Heat transfer in the separating wall of a recuperator generally takes place by

conduction. However, in a heat pipe heat exchanger, the heat pipe not only acts as a separating wall, but also facilitates the transfer of heat by condensation, evaporation, and conduction of the working fluid inside the heat pipe. In general, if the fluids are immiscible, the separating wall may be eliminated, and the interface between the fluids replaces a heat transfer surface, as in a direct-contact heat exchanger.

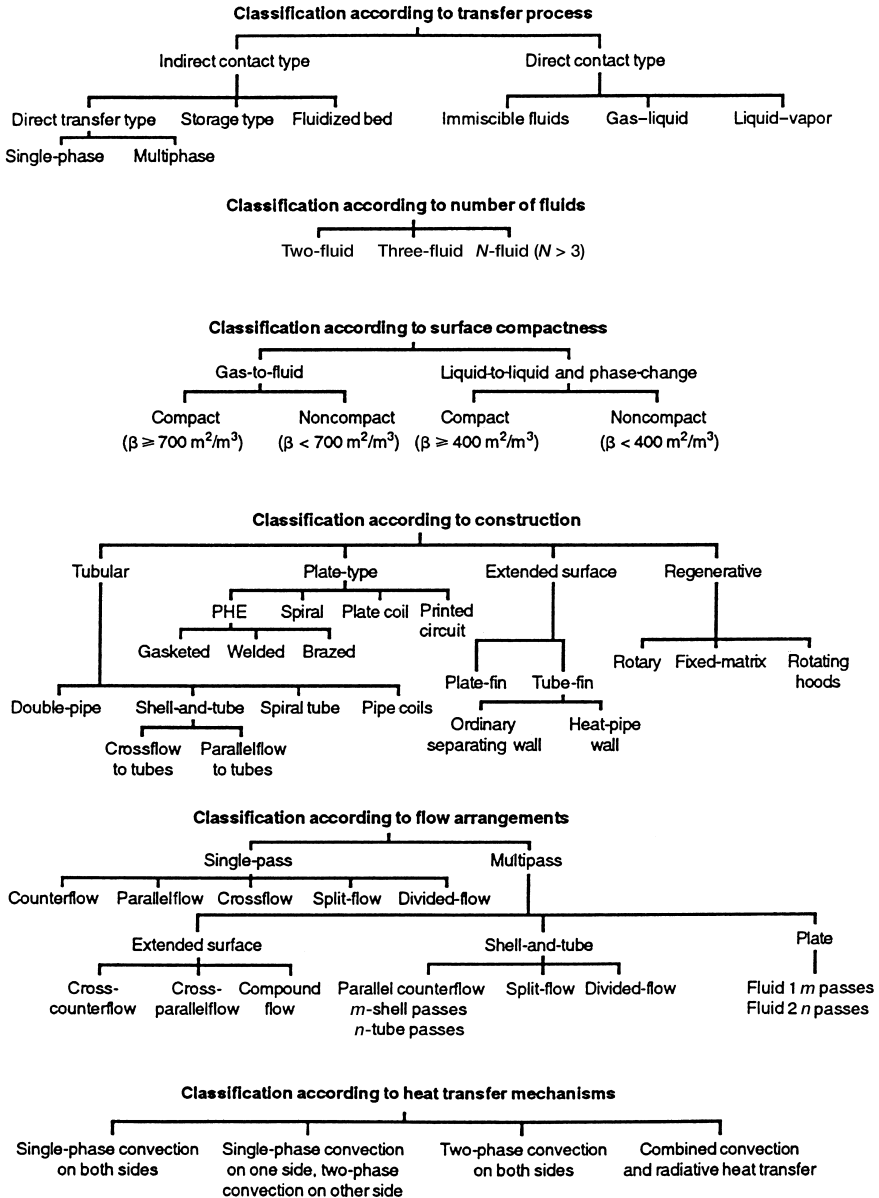

FIGURE 1.1 Classification of heat exchangers (Shah, 1981).

A heat exchanger consists of *heat transfer elements* such as a core or matrix containing the heat transfer surface, and *fluid distribution elements* such as headers, manifolds, tanks, inlet and outlet nozzles or pipes, or seals. Usually, there are no moving parts in a heat exchanger; however, there are exceptions, such as a rotary regenerative exchanger (in which the matrix is mechanically driven to rotate at some design speed) or a scraped surface heat exchanger.

The heat transfer surface is a surface of the exchanger core that is in direct contact with fluids and through which heat is transferred by conduction. That portion of the surface that is in direct contact with both the hot and cold fluids and transfers heat between them is referred to as the *primary* or *direct surface*. To increase the heat transfer area, appendages may be intimately connected to the primary surface to provide an *extended, secondary, or indirect surface*. These extended surface elements are referred to as *fins*. Thus, heat is conducted through the fin and convected (and/or radiated) from the fin (through the surface area) to the surrounding fluid, or vice versa, depending on whether the fin is being cooled or heated. As a result, the addition of fins to the primary surface reduces the thermal resistance on that side and thereby increases the total heat transfer from the surface for the same temperature difference. Fins may form flow passages for the individual fluids but do not separate the two (or more) fluids of the exchanger. These secondary surfaces or fins may also be introduced primarily for structural strength purposes or to provide thorough mixing of a highly viscous liquid.

Not only are heat exchangers often used in the process, power, petroleum, transportation, air-conditioning, refrigeration, cryogenic, heat recovery, alternative fuel, and manufacturing industries, they also serve as key components of many industrial products available in the marketplace. These exchangers can be classified in many different ways. We will classify them according to transfer processes, number of fluids, and heat transfer mechanisms. Conventional heat exchangers are further classified according to construction type and flow arrangements. Another arbitrary classification can be made, based on the heat transfer surface area/volume ratio, into compact and noncompact heat exchangers. This classification is made because the type of equipment, fields of applications, and design techniques generally differ. All these classifications are summarized in Fig. 1.1 and discussed further in this chapter. Heat exchangers can also be classified according to the process function, as outlined in Fig. 1.2. However, they are not discussed here and the reader may refer to Shah and Mueller (1988). Additional ways to classify heat exchangers are by fluid type (gas–gas, gas–liquid, liquid–liquid, gas two-phase, liquid two-phase, etc.), industry, and so on, but we do not cover such classifications in this chapter.

1.2 CLASSIFICATION ACCORDING TO TRANSFER PROCESSES

Heat exchangers are classified according to transfer processes into indirect- and direct-contact types.

1.2.1 Indirect-Contact Heat Exchangers

In an indirect-contact heat exchanger, the fluid streams remain separate and the heat transfers continuously through an impervious dividing wall or into and out of a wall in a transient manner. Thus, ideally, there is no direct contact between thermally interacting fluids. This type of heat exchanger, also referred to as a *surface heat exchanger*, can be further classified into direct-transfer type, storage type, and fluidized-bed exchangers.

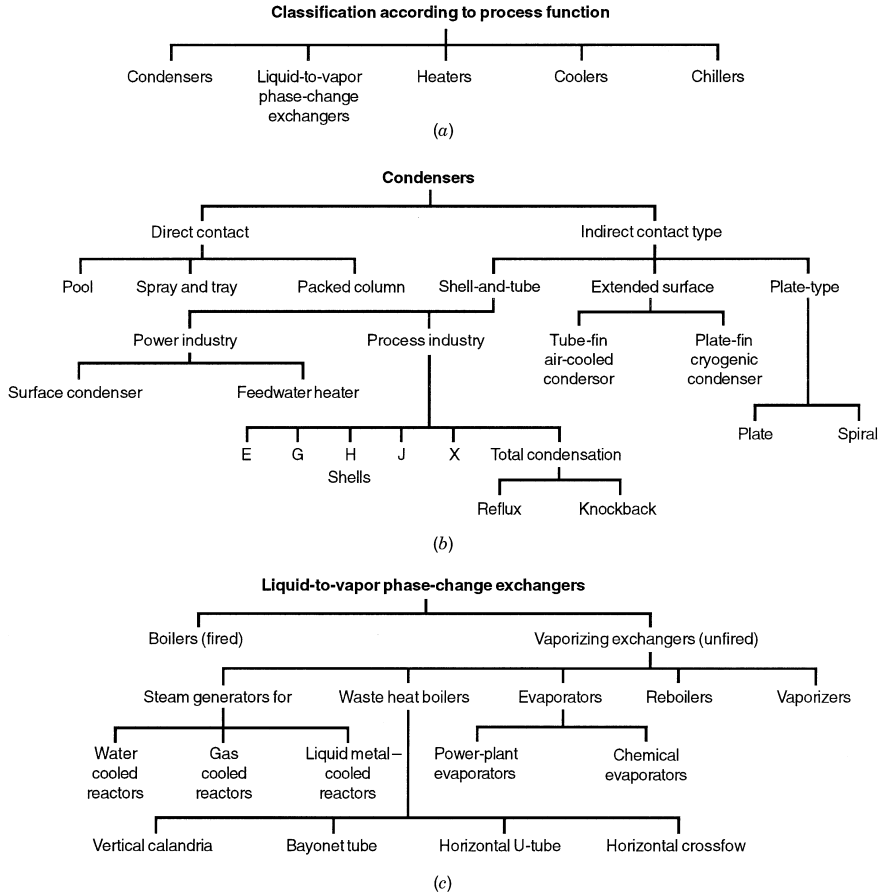

FIGURE 1.2 (a) Classification according to process function; (b) classification of condensers; (c) classification of liquid-to-vapor phase-change exchangers.

1.2.1.1 Direct-Transfer Type Exchangers. In this type, heat transfers continuously from the hot fluid to the cold fluid through a dividing wall. Although a simultaneous flow of two (or more) fluids is required in the exchanger, there is no direct mixing of the two (or more) fluids because each fluid flows in separate fluid passages. In general, there are no moving parts in most such heat exchangers. This type of exchanger is designated as a recuperative heat exchanger or simply as a *recuperator*.[†] Some examples of direct-transfer type heat exchangers are tubular, plate-type, and extended surface exchangers. Note that the term *recuperator* is not commonly used in the process industry for shell-

[†] In vehicular gas turbines, a stationary heat exchanger is usually referred to as a *recuperator*, and a rotating heat exchanger as a *regenerator*. However, in industrial gas turbines, by long tradition and in a thermodynamic sense, a stationary heat exchanger is generally referred to as a regenerator. Hence, a gas turbine *regenerator* could be either a recuperator or a regenerator in a strict sense, depending on the construction. In power plants, a heat exchanger is not called a recuperator, but is, rather, designated by its function or application.

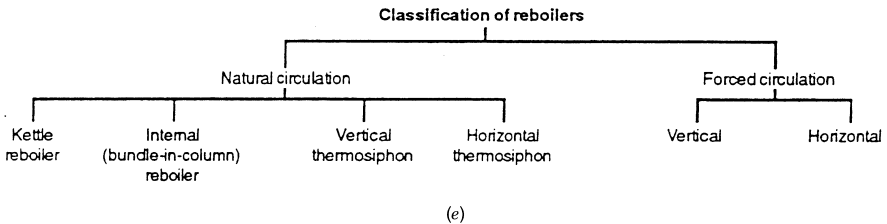
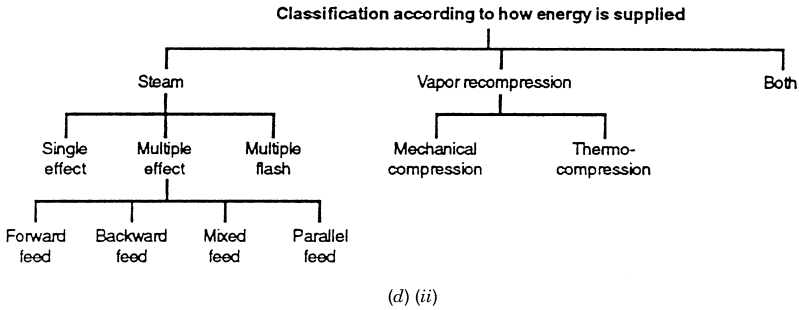
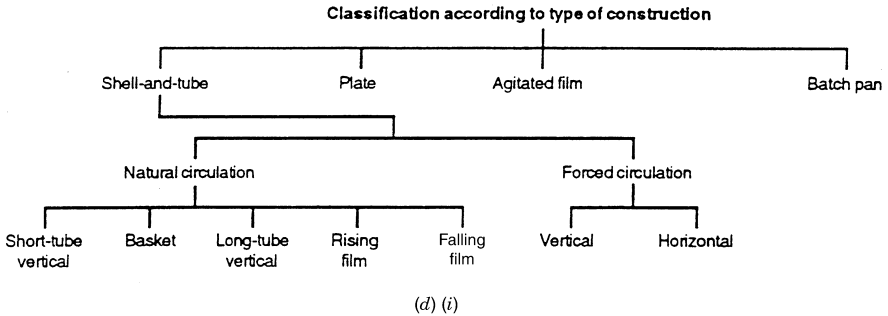

FIGURE 1.2 (d) classification of chemical evaporators according to (i) the type of construction, and (ii) how energy is supplied (Shah and Mueller, 1988); (e) classification of reboilers.

and-tube and plate heat exchangers, although they are also considered as recuperators. Recuperators are further subclassified as prime surface exchangers and extended-surface exchangers. *Prime surface exchangers* do not employ fins or extended surfaces on any fluid side. Plain tubular exchangers, shell-and-tube exchangers with plain tubes, and plate exchangers are good examples of prime surface exchangers. Recuperators constitute a vast majority of all heat exchangers.

1.2.1.2 Storage Type Exchangers. In a storage type exchanger, both fluids flow alternately through the same flow passages, and hence heat transfer is intermittent. The heat transfer surface (or flow passages) is generally cellular in structure and is referred to as a *matrix* (see Fig. 1.43), or it is a permeable (porous) solid material, referred to as a *packed bed*. When hot gas flows over the heat transfer surface (through flow passages),

the thermal energy from the hot gas is stored in the matrix wall, and thus the hot gas is being cooled during the matrix heating period. As cold gas flows through the same passages later (i.e., during the matrix cooling period), the matrix wall gives up thermal energy, which is absorbed by the cold fluid. Thus, heat is not transferred continuously through the wall as in a direct-transfer type exchanger (recuperator), but the corresponding thermal energy is alternately stored and released by the matrix wall. This storage type heat exchanger is also referred to as a *regenerative heat exchanger*, or simply as a *regenerator*.[†] To operate continuously and within a desired temperature range, the gases, headers, or matrices are switched periodically (i.e., rotated), so that the same passage is occupied periodically by hot and cold gases, as described further in Section 1.5.4. The actual time that hot gas takes to flow through a cold regenerator matrix is called the *hot period* or *hot blow*, and the time that cold gas flows through the hot regenerator matrix is called the *cold period* or *cold blow*. For successful operation, it is not necessary to have hot- and cold-gas flow periods of equal duration. There is some unavoidable carryover of a small fraction of the fluid trapped in the passage to the other fluid stream just after switching of the fluids; this is referred to as *carryover leakage*. In addition, if the hot and cold fluids are at different pressures, there will be leakage from the high-pressure fluid to the low-pressure fluid past the radial, peripheral, and axial seals, or across the valves. This leakage is referred to as *pressure leakage*. Since these leaks are unavoidable, regenerators are used exclusively in gas-to-gas heat (and mass) transfer applications with sensible heat transfer; in some applications, regenerators may transfer moisture from humid air to dry air up to about 5%.

For heat transfer analysis of regenerators, the ϵ -NTU method of recuperators needs to be modified to take into account the thermal energy storage capacity of the matrix. We discuss the design theory of regenerators in detail in Chapter 5.

1.2.1.3 Fluidized-Bed Heat Exchangers. In a fluidized-bed heat exchanger, one side of a two-fluid exchanger is immersed in a bed of finely divided solid material, such as a tube bundle immersed in a bed of sand or coal particles, as shown in Fig. 1.3. If the upward fluid velocity on the bed side is low, the solid particles will remain fixed in position in the bed and the fluid will flow through the interstices of the bed. If the upward fluid velocity is high, the solid particles will be carried away with the fluid. At a “proper” value of the fluid velocity, the upward drag force is slightly higher than the weight of the bed particles. As a result, the solid particles will float with an increase in bed volume, and the bed behaves as a liquid. This characteristic of the bed is referred to as a *fluidized condition*. Under this condition, the fluid pressure drop through the bed remains almost constant, independent of the flow rate, and a strong mixing of the solid particles occurs. This results in a uniform temperature for the total bed (gas and particles) with an apparent thermal conductivity of the solid particles as infinity. Very high heat transfer coefficients are achieved on the fluidized side compared to particle-free or dilute-phase particle gas flows. Chemical reaction is common on the fluidized side in many process applications, and combustion takes place in coal combustion fluidized beds. The common applications of the fluidized-bed heat exchanger are drying, mixing, adsorption, reactor engineering, coal combustion, and waste heat recovery. Since the

[†] Regenerators are also used for storing thermal energy for later use, as in the storage of thermal energy. Here the objective is how to store the maximum fraction of the input energy and minimize heat leakage. However, we do not concentrate on this application in this book.

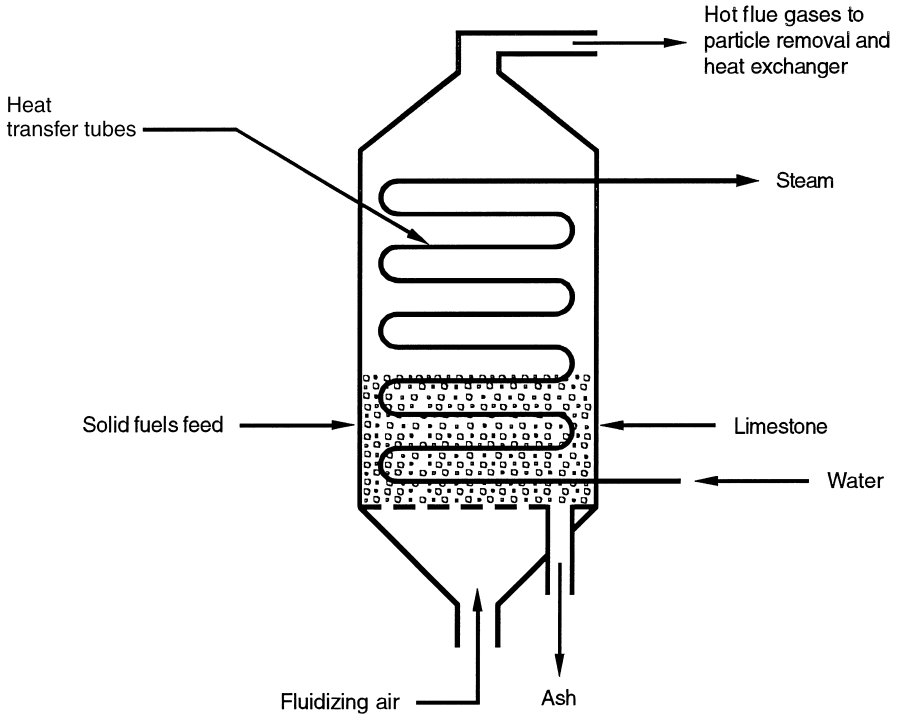

FIGURE 1.3 Fluidized-bed heat exchanger.

initial temperature difference $(T_{h,i} - T_{f,i})^\dagger$ is reduced due to fluidization, the exchanger effectiveness is lower, and hence ε -NTU theory for a fluidized-bed exchanger needs to be modified (Suo, 1976). Chemical reaction and combustion further complicate the design of these exchangers but are beyond the scope of this book.

1.2.2 Direct-Contact Heat Exchangers

In a direct-contact exchanger, two fluid streams come into direct contact, exchange heat, and are then separated. Common applications of a direct-contact exchanger involve mass transfer in addition to heat transfer, such as in evaporative cooling and rectification; applications involving only sensible heat transfer are rare. The enthalpy of phase change in such an exchanger generally represents a significant portion of the total energy transfer. The phase change generally enhances the heat transfer rate. Compared to indirect-contact recuperators and regenerators, in direct-contact heat exchangers, (1) very high heat transfer rates are achievable, (2) the exchanger construction is relatively inexpensive, and (3) the fouling problem is generally nonexistent, due to the absence of a heat transfer surface (wall) between the two fluids. However, the applications are limited to those cases where a direct contact of two fluid streams is permissible. The design theory for these

[†] $T_{h,i}$, inlet temperature of the hot fluid to the fluidized bed; $T_{f,i}$, temperature of the fluidized bed itself at the inlet.

exchangers is beyond the scope of this book and is not covered. These exchangers may be further classified as follows.

1.2.2.1 Immiscible Fluid Exchangers. In this type, two immiscible fluid streams are brought into direct contact. These fluids may be single-phase fluids, or they may involve condensation or vaporization. Condensation of organic vapors and oil vapors with water or air are typical examples.

1.2.2.2 Gas–Liquid Exchangers. In this type, one fluid is a gas (more commonly, air) and the other a low-pressure liquid (more commonly, water) and are readily separable after the energy exchange. In either cooling of liquid (water) or humidification of gas (air) applications, liquid partially evaporates and the vapor is carried away with the gas. In these exchangers, more than 90% of the energy transfer is by virtue of mass transfer (due to the evaporation of the liquid), and convective heat transfer is a minor mechanism. A “wet” (water) cooling tower with forced- or natural-draft airflow is the most common application. Other applications are the air-conditioning spray chamber, spray drier, spray tower, and spray pond.

1.2.2.3 Liquid–Vapor Exchangers. In this type, typically steam is partially or fully condensed using cooling water, or water is heated with waste steam through direct contact in the exchanger. Noncondensables and residual steam and hot water are the outlet streams. Common examples are desuperheaters and open feedwater heaters (also known as *deaerators*) in power plants.

1.3 CLASSIFICATION ACCORDING TO NUMBER OF FLUIDS

Most processes of heating, cooling, heat recovery, and heat rejection involve transfer of heat between two fluids. Hence, two-fluid heat exchangers are the most common. Three-fluid heat exchangers are widely used in cryogenics and some chemical processes (e.g., air separation systems, a helium–air separation unit, purification and liquefaction of hydrogen, ammonia gas synthesis). Heat exchangers with as many as 12 fluid streams have been used in some chemical process applications. The design theory of three- and multifluid heat exchangers is algebraically very complex and is not covered in this book. Exclusively, only the design theory for two-fluid exchangers and some associated problems are presented in this book.

1.4 CLASSIFICATION ACCORDING TO SURFACE COMPACTNESS

Compared to shell-and-tube exchangers, compact heat exchangers are characterized by a large heat transfer surface area per unit volume of the exchanger, resulting in reduced space, weight, support structure and footprint, energy requirements and cost, as well as improved process design and plant layout and processing conditions, together with low fluid inventory.

A gas-to-fluid exchanger is referred to as a *compact heat exchanger* if it incorporates a heat transfer surface having a surface area density greater than about $700 \text{ m}^2/\text{m}^3$

(213 ft²/ft³)[†] or a hydraulic diameter $D_h \leq 6$ mm ($\frac{1}{4}$ in.) for operating in a gas stream and 400 m²/m³ (122 ft²/ft³) or higher for operating in a liquid or phase-change stream. A *laminar flow heat exchanger* (also referred to as a *meso heat exchanger*) has a surface area density greater than about 3000 m²/m³ (914 ft²/ft³) or $100 \mu\text{m} \leq D_h \leq 1$ mm. The term *micro heat exchanger* is used if the surface area density is greater than about 15,000 m²/m³ (4570 ft²/ft³) or $1 \mu\text{m} \leq D_h \leq 100 \mu\text{m}$. A liquid/two-phase fluid heat exchanger is referred to as a *compact heat exchanger* if the surface area density on any one fluid side is greater than about 400 m²/m³. In contrast, a typical process industry shell-and-tube exchanger has a surface area density of less than 100 m²/m³ on one fluid side with plain tubes, and two to three times greater than that with high-fin-density low-finned tubing. A typical plate heat exchanger has about twice the average heat transfer coefficient h on one fluid side or the average overall heat transfer coefficient U than that for a shell-and-tube exchanger for water/water applications. A compact heat exchanger is *not* necessarily of small bulk and mass. However, if it did not incorporate a surface of high-surface-area density, it would be much more bulky and massive. Plate-fin, tube-fin, and rotary regenerators are examples of compact heat exchangers for gas flow on one or both fluid sides, and gasketed, welded, brazed plate heat exchangers and printed-circuit heat exchangers are examples of compact heat exchangers for liquid flows. Basic flow arrangements of two-fluid compact heat exchangers are single-pass crossflow, counterflow, and multipass cross-counterflow (see Section 1.6 for details); for noncompact heat exchangers, many other flow arrangements are also used. The aforementioned last two flow arrangements for compact or noncompact heat exchangers can yield a very high exchanger effectiveness value or a very small temperature approach (see Section 3.2.3 for the definition) between fluid streams.

A spectrum of surface area density of heat exchanger surfaces is shown in Fig. 1.4. On the bottom of the figure, two scales are shown: the heat transfer surface area density β (m²/m³) and the hydraulic diameter D_h ,[‡] (mm), which is the tube inside or outside diameter D (mm) for a thin-walled circular tube. Different heat exchanger surfaces are shown in the rectangles. When projected on the β (or D_h) scale, the short vertical sides of a rectangle indicate the range of surface area density (or hydraulic diameter) for the particular surface in question. What is referred to as β in this figure is either β_1 or β_2 , defined as follows. For plate heat exchangers, plate-fin exchangers, and regenerators,

$$\beta_1 = \frac{A_h}{V_h} \quad \text{or} \quad \frac{A_c}{V_c} \quad (1.1)$$

For tube-fin exchangers and shell-and-tube exchangers,

$$\beta_2 = \frac{A_h}{V_{\text{total}}} \quad \text{or} \quad \frac{A_c}{V_{\text{total}}} \quad (1.2)$$

[†]The unit conversion throughout the book may not be exact; it depends on whether the number is exact or is an engineering value.

[‡]The hydraulic diameter is defined as $4A_o/P$, where A_o is the minimum free-flow area on one fluid side of a heat exchanger and P is the wetted perimeter of flow passages of that side. Note that the wetted perimeter can be different for heat transfer and pressure drop calculations. For example, the hydraulic diameter for an annulus of a double-pipe heat exchanger for q and Δp calculations is as follows.

$$D_{h,q} = \frac{4(\pi/4)(D_o^2 - D_i^2)}{\pi D_i} = \frac{D_o^2 - D_i^2}{D_i} \quad D_{h,\Delta p} = \frac{4(\pi/4)(D_o^2 - D_i^2)}{\pi(D_o + D_i)} = D_o - D_i$$

where D_o is the inside diameter of the outer pipe and D_i is the outside diameter of the inside pipe of a double-pipe exchanger. See also Eq. (3.65) for a more precise definition of the hydraulic diameter.

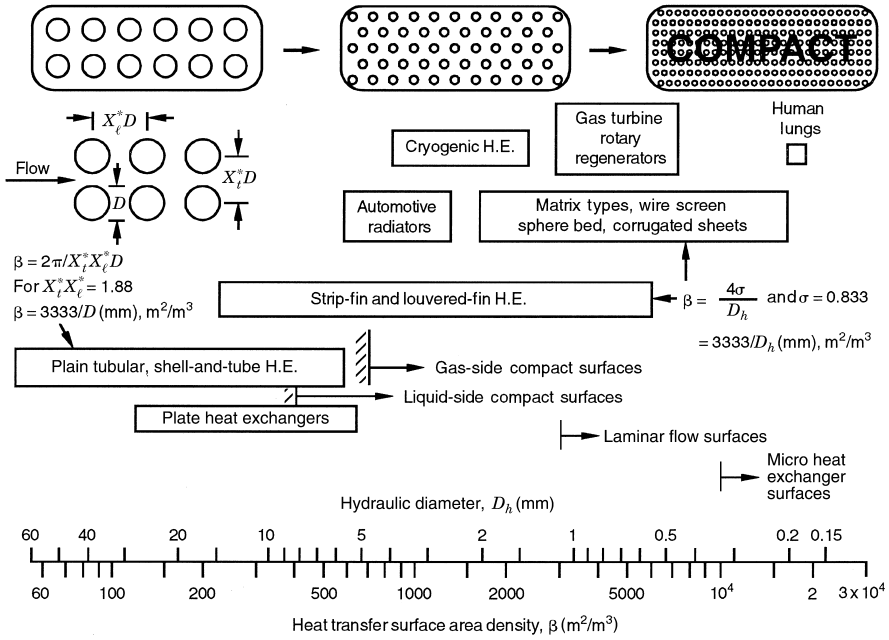

FIGURE 1.4 Heat transfer surface area density spectrum of exchanger surfaces (Shah, 1981).

Here A is the heat transfer surface area, V the exchanger volume, and the subscripts h and c denote hot and cold fluid sides, respectively. V_h and V_c are the volumes individually occupied by the hot- and cold-fluid-side heat transfer surfaces. From this point on in the book, β_1 is simply designated as β and β_2 is designated as α :

$$\beta = \beta_1 \quad \alpha = \beta_2 \tag{1.3}$$

Note that both β and α (with the definitions noted above) are used in defining the surface area densities of a plate-fin surface; however, only α is used in defining the surface area density of a tube-fin surface since β has no meaning in this case. The following specific values are used in preparing Fig. 1.4:

- For a shell-and-tube exchanger, an inline arrangement[†] is considered with $X_t^*X_l^* = 1.88$.
- For plate and plate-fin exchangers, the porosity between plates is taken as 0.8333; and for a regenerator, the porosity of matrix surface is taken as 0.8333. With these values, β (m^2/m^3) and D_h (mm) are related as $\beta = 3333/D_h$.

[†] The tube array is idealized as infinitely large with thin-walled circular tubes. X_t^* and X_l^* are the transverse and longitudinal tube pitches normalized with respect to the tube outside diameter. Refer to Table 8.1 for the definitions of tube pitches.

Note that some industries quote the total surface area (of hot- and cold-fluid sides) in their exchanger specifications. However, in calculations of heat exchanger design, we need individual fluid-side heat transfer surface areas; and hence we use here the definitions of β and α as given above.

Based on the foregoing definition of a compact surface, a tube bundle having 5 mm (0.2 in.) diameter tubes in a shell-and-tube exchanger comes close to qualifying as a compact exchanger. As β or α varies inversely with the tube diameter, the 25.4 mm (1 in.) diameter tubes used in a power plant condenser result in a noncompact exchanger. In contrast, a 1990s automobile radiator [790 fins/m (20 fins/in.)] has a surface area density β on the order of $1870 \text{ m}^2/\text{m}^3$ ($570 \text{ ft}^2/\text{ft}^3$) on the air side, which is equivalent to 1.8 mm (0.07 in.) diameter tubes. The regenerators in some vehicular gas turbine engines under development have matrices with an area density on the order of $6600 \text{ m}^2/\text{m}^3$ ($2000 \text{ ft}^2/\text{ft}^3$), which is equivalent to 0.5 mm (0.02 in.) diameter tubes in a bundle. Human lungs are one of the most compact heat-and-mass exchangers, having a surface area density of about $17,500 \text{ m}^2/\text{m}^3$ ($5330 \text{ ft}^2/\text{ft}^3$), which is equivalent to 0.19 mm (0.0075 in.) diameter tubes. Some micro heat exchangers under development are as compact as the human lung (Shah, 1991a) and also even more compact.

The motivation for using compact surfaces is to gain specified heat exchanger performance, $q/\Delta T_m$, within acceptably low mass and box volume constraints. The heat exchanger performance may be expressed as

$$\frac{q}{\Delta T_m} = UA = U\beta V \quad (1.4)$$

where q is the heat transfer rate, ΔT_m the true mean temperature difference, and U the overall heat transfer coefficient. Clearly, a high β value minimizes exchanger volume V for specified $q/\Delta T_m$. As explained in Section 7.4.1.1, compact surfaces (having small D_h) generally result in a higher heat transfer coefficient and a higher overall heat transfer coefficient U , resulting in a smaller volume. As compact surfaces can achieve structural stability and strength with thinner-gauge material, the gain in a lower exchanger mass is even more pronounced than the gain in a smaller volume.

1.4.1 Gas-to-Fluid Exchangers

The heat transfer coefficient h for gases is generally one or two orders of magnitude lower than that for water, oil, and other liquids. Now, to minimize the size and weight of a gas-to-liquid heat exchanger, the thermal conductances (hA products) on both sides of the exchanger should be approximately the same. Hence, the heat transfer surface on the gas side needs to have a much larger area and be more compact than can be realized practically with the circular tubes commonly used in shell-and-tube exchangers. Thus, for an approximately balanced design (about the same hA values), a compact surface is employed on the gas side of gas-to-gas, gas-to-liquid, and gas-to-phase change heat exchangers.

The unique characteristics of compact extended-surface (plate-fin and tube-fin) exchangers, compared to conventional shell-and-tube exchangers (see Fig. 1.6), are as follows:

- Availability of numerous surfaces having different orders of magnitude of surface area density

- Flexibility in distributing surface area on the hot and cold sides as warranted by design considerations
- Generally, substantial cost, weight, or volume savings.

The important design and operating considerations for compact extended-surface exchangers are as follows:

- Usually, at least one of the fluids is a gas having a low h value.
- Fluids must be clean and relatively noncorrosive because of low- D_h flow passages and no easy techniques for cleaning.
- The fluid pumping power (and hence the pressure drop) is often as important as the heat transfer rate.
- Operating pressures and temperatures are somewhat limited compared to shell-and-tube exchangers, due to joining of the fins to plates or tubes by brazing, mechanical expansion, and so on.
- With the use of highly compact surfaces, the resulting shape of the exchanger is one having a large frontal area and a short flow length; the header design of a compact heat exchanger is thus important for achieving uniform flow distribution among very large numbers of small flow passages.
- The market potential must be large enough to warrant the sizable initial manufacturing tooling and equipment costs.

Fouling is a major potential problem in compact heat exchangers (except for plate-and-frame heat exchangers), particularly those having a variety of fin geometries or very fine circular or noncircular flow passages that cannot be cleaned mechanically. Chemical cleaning may be possible; thermal baking and subsequent rinsing are possible for small units.[†] Hence, extended-surface compact heat exchangers may not be used in heavy fouling applications. Nonfouling fluids are used where permissible, such as clean air or gases, light hydrocarbons, and refrigerants.

1.4.2 Liquid-to-Liquid and Phase-Change Exchangers

Liquid-to-liquid and phase-change exchangers are gasketed plate-and-frame and welded plate, spiral plate, and printed-circuit exchangers. Some of them are described in detail in Section 1.5.2.

1.5 CLASSIFICATION ACCORDING TO CONSTRUCTION FEATURES

Heat exchangers are frequently characterized by construction features. Four major construction types are tubular, plate-type, extended surface, and regenerative exchangers. Heat exchangers with other constructions are also available, such as scraped surface exchanger, tank heater, cooler cartridge exchanger, and others (Walker, 1990). Some of these may be classified as tubular exchangers, but they have some unique features compared to conventional tubular exchangers. Since the applications of these exchangers

[†] Some additional techniques for cleaning and mitigation of fouling are summarized in Section 13.4.

are specialized, we concentrate here only on the four major construction types noted above.

Although the ε -NTU and MTD methods (see end of Section 3.2.2) are identical for tubular, plate-type, and extended-surface exchangers, the influence of the following factors must be taken into account in exchanger design: corrections due to leakage and bypass streams in a shell-and-tube exchanger, effects due to a few plates in a plate exchanger, and fin efficiency in an extended-surface exchanger. Similarly, the ε -NTU method must be modified to take into account the heat capacity of the matrix in a regenerator. Thus, the detailed design theory differs for each construction type and is discussed in detail in Chapters 3 through 5. Let us first discuss the construction features of the four major types.

1.5.1 Tubular Heat Exchangers

These exchangers are generally built of circular tubes, although elliptical, rectangular, or round/flat twisted tubes have also been used in some applications. There is considerable flexibility in the design because the core geometry can be varied easily by changing the tube diameter, length, and arrangement. Tubular exchangers can be designed for high pressures relative to the environment and high-pressure differences between the fluids. Tubular exchangers are used primarily for liquid-to-liquid and liquid-to-phase change (condensing or evaporating) heat transfer applications. They are used for gas-to-liquid and gas-to-gas heat transfer applications primarily when the operating temperature and/or pressure is very high or fouling is a severe problem on at least one fluid side and no other types of exchangers would work. These exchangers may be classified as shell-and-tube, double-pipe, and spiral tube exchangers. They are all prime surface exchangers except for exchangers having fins outside/inside tubes.

1.5.1.1 Shell-and-Tube Exchangers. This exchanger, shown in Fig. 1.5, is generally built of a bundle of round tubes mounted in a cylindrical shell with the tube axis parallel to that of the shell. One fluid flows inside the tubes, the other flows across and along the tubes. The major components of this exchanger are tubes (or tube bundle), shell, front-end head, rear-end head, baffles, and tubesheets, and are described briefly later in this subsection. For further details, refer to Section 10.2.1.

A variety of different internal constructions are used in shell-and-tube exchangers, depending on the desired heat transfer and pressure drop performance and the methods employed to reduce thermal stresses, to prevent leakages, to provide for ease of cleaning, to contain operating pressures and temperatures, to control corrosion, to accommodate highly asymmetric flows, and so on. Shell-and-tube exchangers are classified and constructed in accordance with the widely used TEMA (Tubular Exchanger Manufacturers Association) standards (TEMA, 1999), DIN and other standards in Europe and elsewhere, and ASME (American Society of Mechanical Engineers) boiler and pressure vessel codes. TEMA has developed a notation system to designate major types of shell-and-tube exchangers. In this system, each exchanger is designated by a three-letter combination, the first letter indicating the front-end head type, the second the shell type, and the third the rear-end head type. These are identified in Fig. 1.6. Some common shell-and-tube exchangers are AES, BEM, AEP, CFU, AKT, and AJW. It should be emphasized that there are other special types of shell-and-tube exchangers commercially available that have front- and rear-end heads different from those in Fig. 1.6. Those exchangers may not be identifiable by the TEMA letter designation.

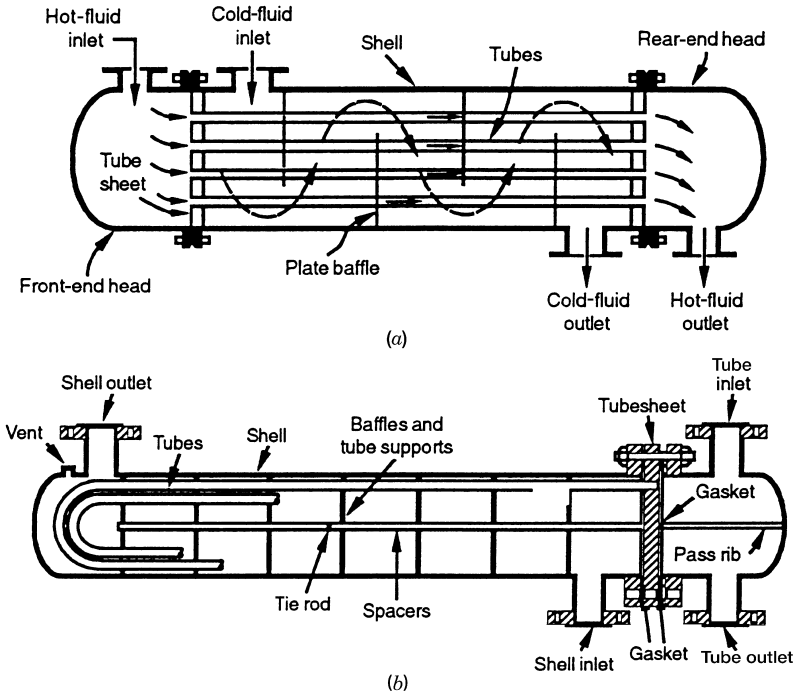

FIGURE 1.5 (a) Shell-and-tube exchanger (BEM) with one shell pass and one tube pass; (b) shell-and-tube exchanger (BEU) with one shell pass and two tube passes.

The three most common types of shell-and-tube exchangers are (1) fixed tubesheet design, (2) U-tube design, and (3) floating-head type. In all three types, the front-end head is stationary while the rear-end head can be either stationary or floating (see Fig. 1.6), depending on the thermal stresses in the shell, tube, or tubesheet, due to temperature differences as a result of heat transfer.

The exchangers are built in accordance with three mechanical standards that specify design, fabrication, and materials of unfired shell-and-tube heat exchangers. Class R is for the generally severe requirements of petroleum and related processing applications. Class C is for generally moderate requirements for commercial and general process applications. Class B is for chemical process service. The exchangers are built to comply with the applicable *ASME Boiler and Pressure Vessel Code*, Section VIII (1998), and other pertinent codes and/or standards. The TEMA standards supplement and define the ASME code for heat exchanger applications. In addition, state and local codes applicable to the plant location must also be met.

The TEMA standards specify the manufacturing tolerances for various mechanical classes, the range of tube sizes and pitches, baffling and support plates, pressure classification, tubesheet thickness formulas, and so on, and must be consulted for all these details. In this book, we consider only the TEMA standards where appropriate, but there are other standards, such as DIN 28 008.

Tubular exchangers are widely used in industry for the following reasons. They are custom designed for virtually any capacity and operating conditions, such as from high



Front-End Stationary Head Types		Shell Types	Rear-End Head Types		
A	 Channel and Removable Cover	E	 One-Pass Shell	L	 Fixed Tubesheet Like "A" Stationary Head
B	 Bonnet (Integral Cover)	F	 Two-Pass Shell with Longitudinal Baffle	M	 Fixed Tubesheet Like "B" Stationary Head
C	 Channel Integral with Tube-Sheet and Removable Cover	G	 Split Flow	N	 Fixed Tubesheet Like "N" Stationary Head
N	 Channel Integral with Tube-Sheet and Removable Cover	H	 Double Split Flow	P	 Outside Packed Floating Head
D	 Special High-Pressure Closure	J	 Divided Flow	S	 Floating Head with Backing Device
		K	 Kettle Type Reboiler	T	 Pull-through Floating Head
		X	 Crossflow	U	 U-Tube Bundle
				W	 Externally Sealed Floating Tubesheet

FIGURE 1.6 Standard shell types and front- and rear-end head types (From TEMA, 1999).

vacuum to ultrahigh pressure [over 100 MPa (15,000 psig)], from cryogenics to high temperatures [about 1100°C (2000°F)] and any temperature and pressure differences between the fluids, limited only by the materials of construction. They can be designed for special operating conditions: vibration, heavy fouling, highly viscous fluids, erosion, corrosion, toxicity, radioactivity, multicomponent mixtures, and so on. They are the most versatile exchangers, made from a variety of metal and nonmetal materials (such as graphite, glass, and Teflon) and range in size from small [0.1 m² (1 ft²)] to supergiant [over 10⁵ m² (10⁶ ft²)] surface area. They are used extensively as process heat exchangers

in the petroleum-refining and chemical industries; as steam generators, condensers, boiler feedwater heaters, and oil coolers in power plants; as condensers and evaporators in some air-conditioning and refrigeration applications; in waste heat recovery applications with heat recovery from liquids and condensing fluids; and in environmental control.

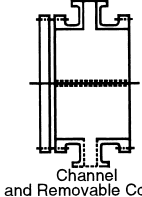
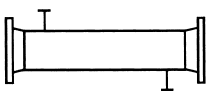
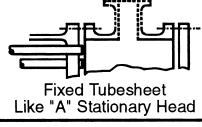
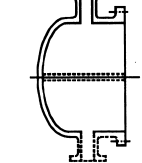
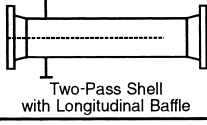
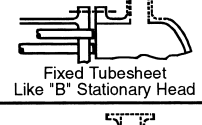
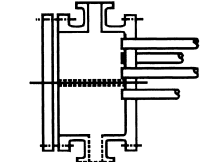
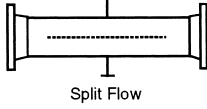
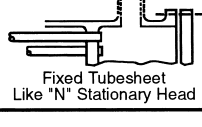
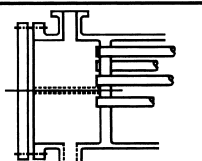
Next, major components of shell-and-tube exchangers are briefly described.

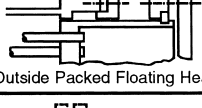
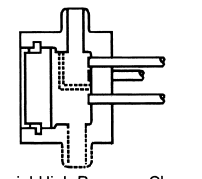
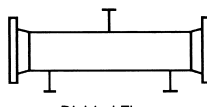
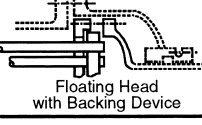
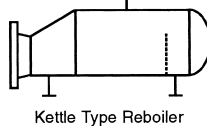
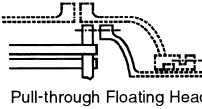
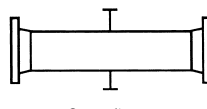
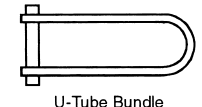
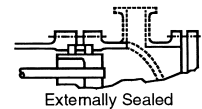
Tubes. Round tubes in various shapes are used in shell-and-tube exchangers. Most common are the tube bundles[†] with straight and U-tubes (Fig. 1.5) used in process and power industry exchangers. However, sine-wave bend, J-shape, L-shape or hockey sticks, and inverted hockey sticks are used in advanced nuclear exchangers to accommodate large thermal expansion of the tubes. Some of the enhanced tube geometries used in shell-and-tube exchangers are shown in Fig. 1.7. Serpentine, helical, and bayonet are other tube shapes (shown in Fig. 1.8) that are used in shell-and-tube exchangers. In most applications, tubes have single walls, but when working with radioactive,

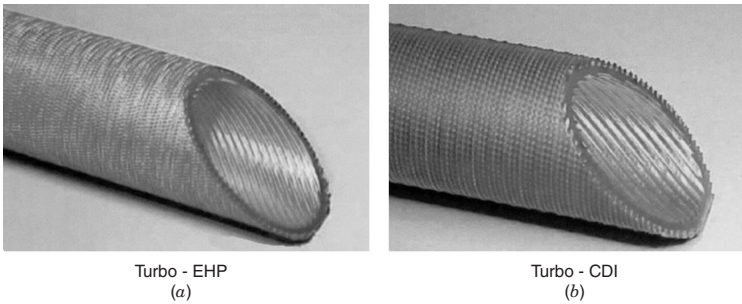

FIGURE 1.7 Some enhanced tube geometries used in shell-and-tube exchangers: (a) internally and externally enhanced evaporator tube; (b) internally and externally enhanced condenser tube. (Courtesy of Wolverine Tube, Inc., Decatur, AL.)

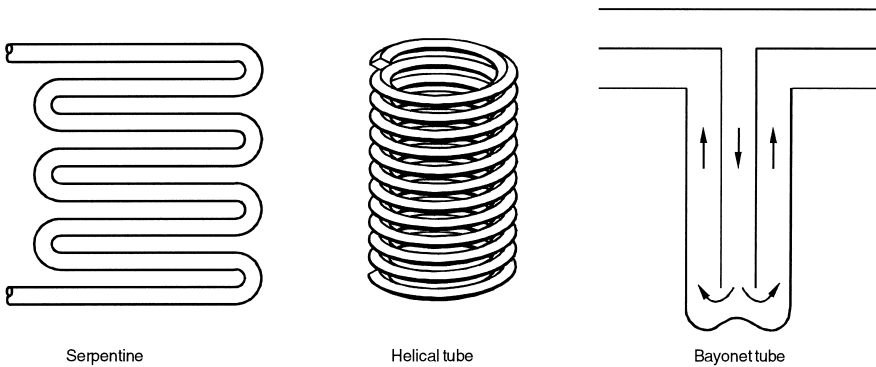

FIGURE 1.8 Additional tube configurations used in shell-and-tube exchangers.

[†] A *tube bundle* is an assembly of tubes, baffles, tubesheets and tie rods, and support plates and longitudinal baffles, if any.

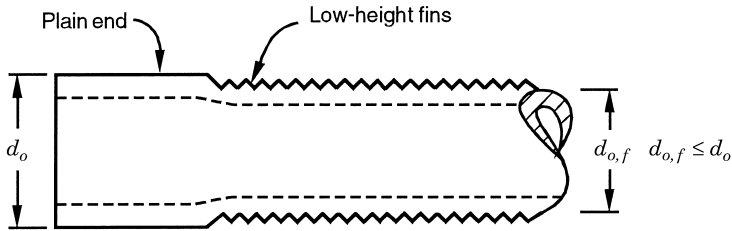

FIGURE 1.9 Low-finned tubing. The plain end goes into the tubesheet.

reactive, or toxic fluids and potable water, double-wall tubing is used. In most applications, tubes are bare, but when gas or low-heat-transfer coefficient liquid is used on the shell side, low-height fins (*low fins*) are used on the shell side. Also, special high-flux-boiling surfaces employ modified low-fin tubing. These are usually integral fins made from a thick-walled tube, shown in Fig. 1.9. Tubes are drawn, extruded, or welded, and they are made from metals, plastics, and ceramics, depending on the applications.

Shells. The shell is a container for the shell fluid.[†] Usually, it is cylindrical in shape with a circular cross section, although shells of different shapes are used in specific applications and in nuclear heat exchangers to conform to the tube bundle shape. The shell is made from a circular pipe if the shell diameter is less than about 0.6 m (2 ft) and is made from a metal plate rolled and welded longitudinally for shell diameters greater than 0.6 m (2 ft). Seven types of shell configurations, standardized by TEMA (1999), are E, F, G, H, J, K, and X, shown in Fig. 1.6. The E shell is the most common, due to its low cost and simplicity, and has the highest log-mean temperature-difference correction factor F (see Section 3.7.2 for the definition). Although the tubes may have single or multiple passes, there is one pass on the shell side. To increase the mean temperature difference and hence exchanger effectiveness, a pure counterflow arrangement is desirable for a two-tube-pass exchanger. This is achieved by use of an F shell having a longitudinal baffle and resulting in two shell passes. Split- and divided-flow shells, such as G, H, and J (see Fig. 1.6), are used for specific applications, such as thermosiphon boiler, condenser, and shell-side low pressure drops. The K shell is a kettle reboiler used for pool boiling applications. The X shell is a crossflow exchanger and is used for low pressure drop on the shell side and/or to eliminate the possibility of flow-induced vibrations. A further description of the various types of shell configurations is provided in Section 10.2.1.4.

Nozzles. The entrance and exit ports for the shell and tube fluids, referred to as *nozzles*, are pipes of constant cross section welded to the shell and channels. They are used to distribute or collect the fluid uniformly on the shell and tube sides. Note that they differ from the nozzle used as a fluid metering device or in jet engines, which has a variable flow area along the flow length.

[†] The fluid flowing in the tubes is referred to as the *tube fluid*; the fluid flowing outside the tubes is referred to as the *shell fluid*.

Front- and Rear-End Heads. These are used for entrance and exit of the tube fluid; in many rear-end heads, a provision has been made to take care of tube thermal expansion. The front-end head is stationary, while the rear-end head could be either stationary (allowing for no tube thermal expansion) or floating, depending on the thermal stresses between the tubes and shell. The major criteria for selection of the front-end head are cost, maintenance and inspection, hazard due to mixing of shell and tube fluids, and leakage to ambient and operating pressures. The major criteria for selection of the rear-end head are the allowance for thermal stresses, a provision to remove the tube bundle for cleaning the shell side, prevention of mixing of tube and shell fluids, and sealing any leakage path for the shell fluid to ambient. The design selection criteria for the front- and rear-end heads of Fig. 1.6 are discussed in Sections 10.2.1.5 and 10.2.1.6.

Baffles. Baffles may be classified as transverse and longitudinal types. The purpose of longitudinal baffles is to control the overall flow direction of the shell fluid such that a desired overall flow arrangement of the two fluid streams is achieved. For example, F, G, and H shells have longitudinal baffles (see Fig. 1.6). Transverse baffles may be classified as plate baffles and grid (rod, strip, and other axial-flow) baffles. Plate baffles are used to support the tubes during assembly and operation and to direct the fluid in the tube bundle approximately at right angles to the tubes to achieve higher heat transfer coefficients. Plate baffles increase the turbulence of the shell fluid and minimize tube-to-tube temperature differences and thermal stresses due to the crossflow. Shown in Fig. 1.10 are single- and multisegmental baffles and disk and doughnut baffles. Single- and double-segmental baffles are used most frequently due to their ability to assist maximum heat transfer (due to a high-shell-side heat transfer coefficient) for a given pressure drop in a minimum amount of space. Triple and no-tubes-in-window segmental baffles are used for low-pressure-drop applications. The choice of baffle type, spacing, and cut is determined largely by flow rate, desired heat transfer rate, allowable pressure drop, tube support, and flow-induced vibrations. Disk and doughnut baffles/support plates are used primarily in nuclear heat exchangers. These baffles for nuclear exchangers have small perforations between tube holes to allow a combination of crossflow and longitudinal flow for lower shell-side pressure drop. The combined flow results in a slightly higher heat transfer coefficient than that for pure longitudinal flow and minimizes tube-to-tube temperature differences. Rod (or bar) baffles, the most common type of grid baffle, used to support the tubes and increase the turbulence of the shell fluid, are shown in Fig. 1.11. The flow in a rod baffle heat exchanger is parallel to the tubes, and flow-induced vibrations are virtually eliminated by the baffle support of the tubes. One alternative to a rod baffle heat exchanger is the use of twisted tubes (after flattening the circular tubes, they are twisted), shown in Fig. 1.12. Twisted tubes provide rigidity and eliminate flow-induced tube vibrations, can be cleaned easily on the shell side with hydrojets, and can be cleaned easily inside the tubes, but cannot be retubed. Low-finned tubes are also available in a twisted-tube configuration. A helical baffle shell-and-tube exchanger with baffles as shown in Fig. 1.13 also has the following advantages: a lower shell-side pressure drop while maintaining the high heat transfer coefficient of a segmental exchanger, reduced leakage streams (see Section 4.4.1), and elimination of dead spots and recirculation zones (thus reducing fouling). Every shell-and-tube exchanger has transverse baffles except for X and K shells, which have support plates because the sole purpose of these transverse baffles is to support the tubes. Baffle types and their design guidelines are described further in Section 10.2.1.3.

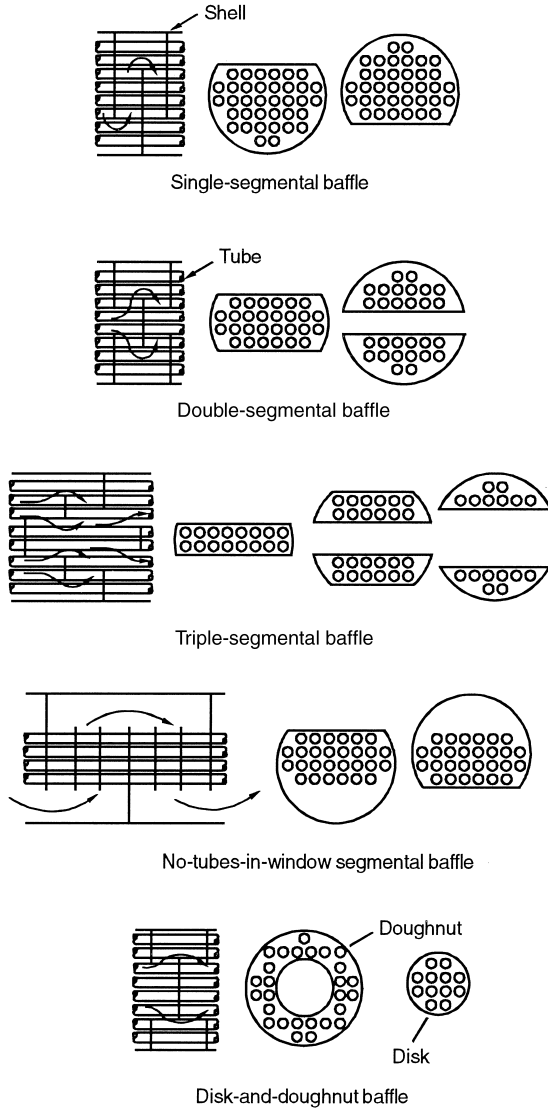

FIGURE 1.10 Plate baffle types, modified from Mueller (1973).

Butterworth (1996) provides further descriptions of these designs, and they are compared in Table 1.1.

Tubesheets. These are used to hold tubes at the ends. A tubesheet is generally a round metal plate with holes drilled through for the desired tube pattern, holes for the tie rods (which are used to space and hold plate baffles), grooves for the gaskets, and bolt holes for flanging to the shell and channel. To prevent leakage of the shell fluid at the

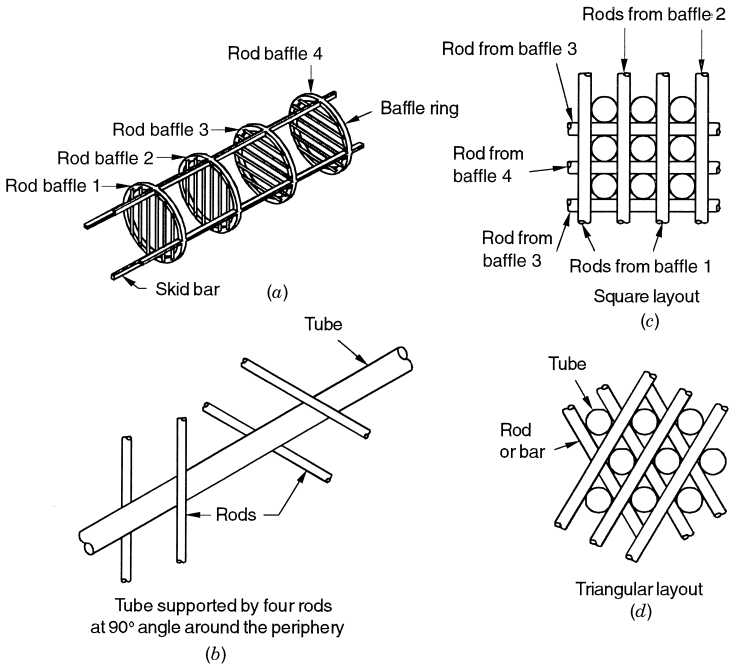

FIGURE 1.11 (a) Four rod baffles held by skid bars (no tubes shown); (b) tube in a rod baffle exchanger supported by four rods; (c) square layout of tubes with rods; (d) triangular layout of tubes with rods (Shah, 1981).

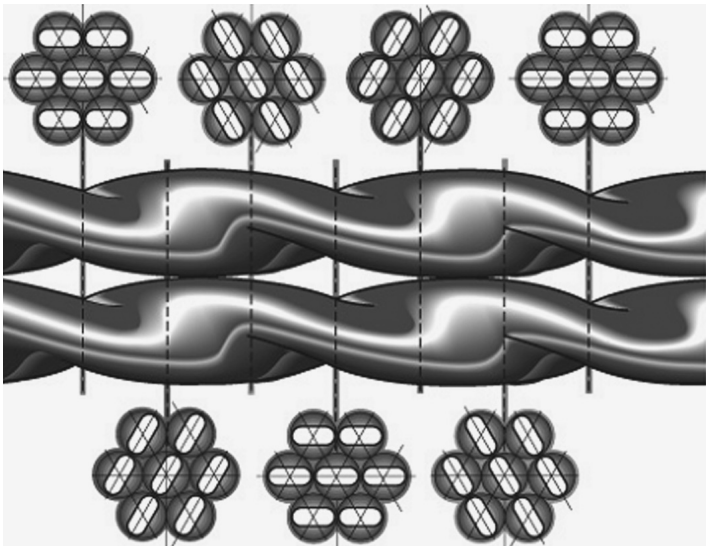

FIGURE 1.12 Twisted tube bundle for a shell-and-tube exchanger. (Courtesy of Brown Fintube Company, Houston, TX.)

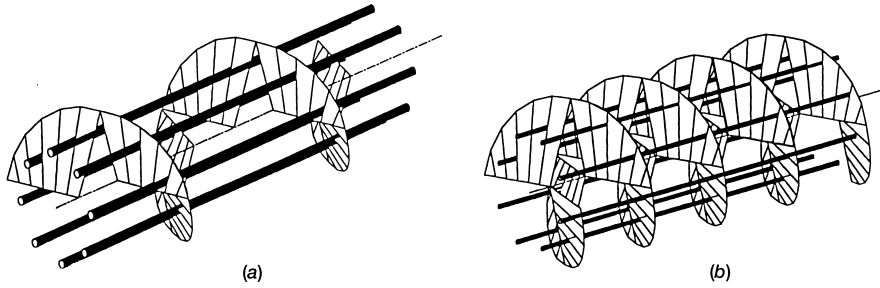

FIGURE 1.13 Helical baffle shell-and-tube exchanger: (a) single helix; (b) double helix. (Courtesy of ABB Lumus Heat Transfer, Bloomfield, NJ.)

tubesheet through a clearance between the tube hole and tube, the tube-to-tubesheet joints are made by many methods, such as expanding the tubes, rolling the tubes, hydraulic expansion of tubes, explosive welding of tubes, stuffing of the joints, or welding or brazing of tubes to the tubesheet. The leak-free tube-to-tubesheet joint made by the conventional rolling process is shown in Fig. 1.14.

1.5.1.2 Double-Pipe Heat Exchangers. This exchanger usually consists of two concentric pipes with the inner pipe plain or finned, as shown in Fig. 1.15. One fluid flows in the inner pipe and the other fluid flows in the annulus between pipes in a counterflow direction for the ideal highest performance for the given surface area. However, if the application requires an almost constant wall temperature, the fluids may flow in a parallelflow direction. This is perhaps the simplest heat exchanger. Flow distribution is no problem, and cleaning is done very easily by disassembly. This configuration is also suitable where one or both of the fluids is at very high pressure,

TABLE 1.1 Comparison of Various Types of Shell-and-Tube Heat Exchangers

Characteristic	Segmental Baffle	Rod Baffle	Twisted Tube	Helical Baffle
Good heat transfer per unit pressure drop	No	Yes	Yes	Yes
High shell-side heat transfer coefficient	Yes	No	No	Yes
Tube-side enhancement	With inserts	With inserts	Included	With inserts
Suitable for very high exchanger effectiveness	No	Yes	Yes	No
Tends to have low fouling	No	Yes	Yes	Yes
Can be cleaned mechanically	Yes, with square pitch	Yes	Yes	Yes, with square pitch
Low flow-induced tube vibration	With special designs	Yes	Yes	With double helix
Can have low-finned tubes	Yes	Yes	Yes	Yes

Source: Data from Butterworth with private communication (2002).

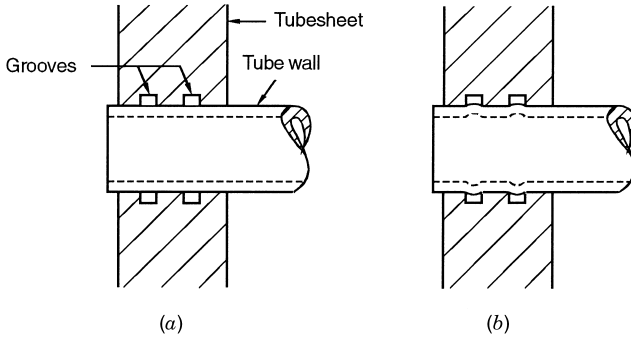

FIGURE 1.14 Details of a leak-free joint between the tube and tube hole of a tubesheet: (a) before tube expansion; (b) after tube expansion.

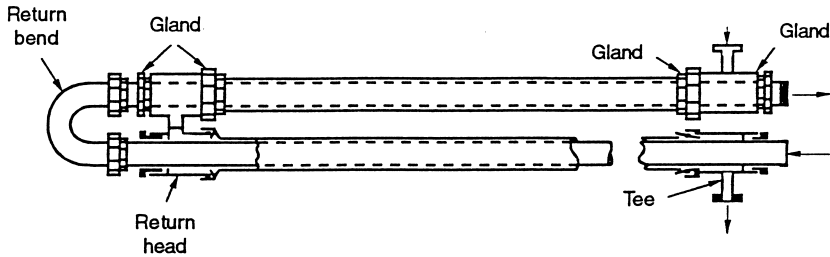

FIGURE 1.15 Double-pipe heat exchanger.

because containment in the small-diameter pipe or tubing is less costly than containment in a large-diameter shell. Double-pipe exchangers are generally used for small-capacity applications where the total heat transfer surface area required is 50 m^2 (500 ft^2) or less because it is expensive on a cost per unit surface area basis. Stacks of double-pipe or multitube heat exchangers are also used in some process applications with radial or longitudinal fins. The exchanger with a bundle of U tubes in a pipe (shell) of 150 mm (6 in.) diameter and above uses segmental baffles and is referred to variously as a *hairpin* or *jacketed U-tube exchanger*.

1.5.1.3 Spiral Tube Heat Exchangers. These consist of one or more spirally wound coils fitted in a shell. Heat transfer rate associated with a spiral tube is higher than that for a straight tube. In addition, a considerable amount of surface can be accommodated in a given space by spiraling. Thermal expansion is no problem, but cleaning is almost impossible.

1.5.2 Plate-Type Heat Exchangers

Plate-type heat exchangers are usually built of thin plates (all prime surface). The plates are either smooth or have some form of corrugation, and they are either flat or wound in an exchanger. Generally, these exchangers cannot accommodate very high pressures,

temperatures, or pressure and temperature differences. Plate heat exchangers (PHEs)[†] can be classified as gasketed, welded (one or both fluid passages), or brazed, depending on the leak tightness required. Other plate-type exchangers are spiral plate, lamella, and platecoil exchangers. These are described next.

1.5.2.1 Gasketed Plate Heat Exchangers

Basic Construction. The plate-and-frame or gasketed plate heat exchanger (PHE) consists of a number of thin rectangular metal plates sealed around the edges by gaskets and held together in a frame as shown in Fig. 1.16. The frame usually has a fixed end cover (headpiece) fitted with connecting ports and a movable end cover (pressure plate, follower, or tailpiece). In the frame, the plates are suspended from an upper carrying bar and guided by a bottom carrying bar to ensure proper alignment. For this purpose, each plate is notched at the center of its top and bottom edges. The plate pack with fixed and movable end covers is clamped together by long bolts, thus compressing the gaskets and forming a seal. For later discussion, we designate the resulting length of the plate pack as L_{pack} . The carrying bars are longer than the compressed stack, so that when the movable end cover is removed, plates may be slid along the support bars for inspection and cleaning.

Each plate is made by stamping or embossing a corrugated (or wavy) surface pattern on sheet metal. On one side of each plate, special grooves are provided along the periphery of the plate and around the ports for a gasket, as indicated by the dark lines in Fig. 1.17. Typical plate geometries (corrugated patterns) are shown in Fig. 1.18, and over 60 different patterns have been developed worldwide. Alternate plates are assembled such

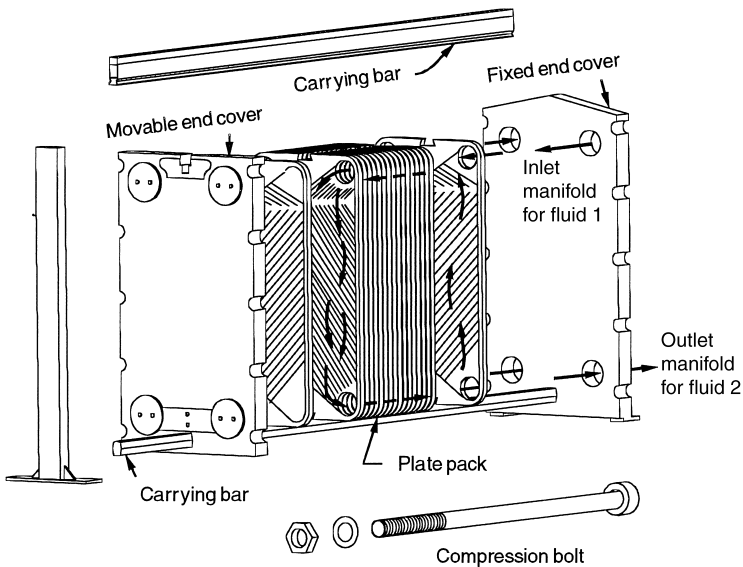

FIGURE 1.16 Gasketed plate- and-frame heat exchanger.

[†] Unless explicitly mentioned, PHE means gasketed plate heat exchanger.

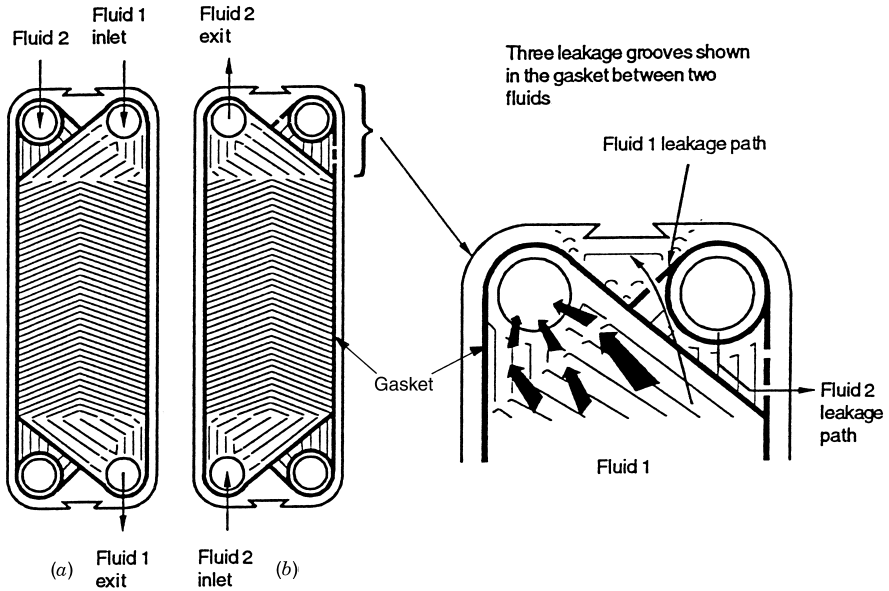

FIGURE 1.17 Plates showing gaskets around the ports (Shah and Focke, 1988).

that the corrugations on successive plates contact or cross each other to provide mechanical support to the plate pack through a large number of contact points. The resulting flow passages are narrow, highly interrupted, and tortuous, and enhance the heat transfer rate and decrease fouling resistance by increasing the shear stress, producing secondary flow, and increasing the level of turbulence. The corrugations also improve the rigidity of the plates and form the desired plate spacing. Plates are designated as *hard* or *soft*, depending on whether they generate a high or low intensity of turbulence.

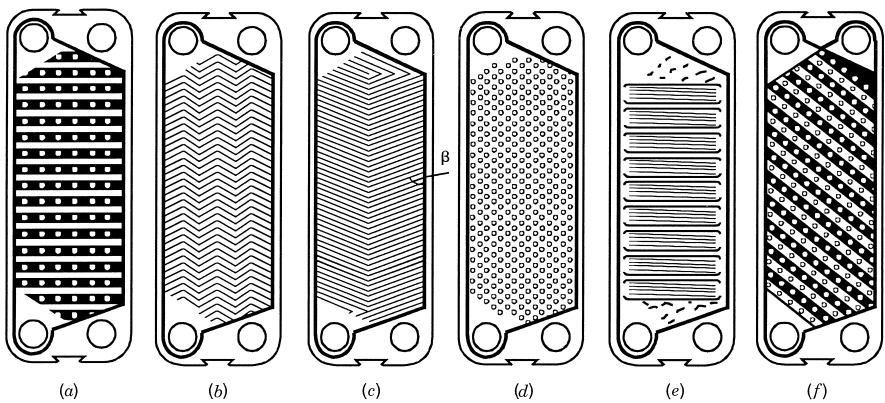

FIGURE 1.18 Plate patterns: (a) washboard; (b) zigzag; (c) chevron or herringbone; (d) protrusions and depressions; (e) washboard with secondary corrugations; (f) oblique washboard (Shah and Focke, 1988).

Sealing between the two fluids is accomplished by elastomeric molded gaskets [typically, 5 mm (0.2 in.) thick] that are fitted in peripheral grooves mentioned earlier (dark lines in Fig. 1.17). Gaskets are designed such that they compress about 25% of thickness in a bolted plate exchanger to provide a leaktight joint without distorting the thin plates. In the past, the gaskets were cemented in the grooves, but now, snap-on gaskets, which do not require cementing, are common. Some manufacturers offer special interlocking types to prevent gasket blowout at high pressure differences. Use of a double seal around the port sections, shown in Fig. 1.17, prevents fluid intermixing in the rare event of gasket failure. The interspace between the seals is also vented to the atmosphere to facilitate visual indication of leakage (Fig. 1.17). Typical gasket materials and their range of applications are listed in Table 1.2, with butyl and nitrile rubber being most common. PTFE (polytetrafluoroethylene) is not used because of its viscoelastic properties.

Each plate has four corner ports. In pairs, they provide access to the flow passages on either side of the plate. When the plates are assembled, the corner ports line up to form distribution headers for the two fluids. Inlet and outlet nozzles for the fluids, provided in the end covers, line up with the ports in the plates (distribution headers) and are connected to external piping carrying the two fluids. A fluid enters at a corner of one end of the compressed stack of plates through the inlet nozzle. It passes through alternate channels[†] in either series or parallel passages. In one set of channels, the gasket does not surround the inlet port between two plates (see, e.g., Fig. 1.17*a* for the fluid 1 inlet port); fluid enters through that port, flows between plates, and exits through a port at the other end. On the same side of the plates, the other two ports are blocked by a gasket with a double seal, as shown in Fig. 1.17*a*, so that the other fluid (fluid 2 in Fig. 1.17*a*) cannot enter the plate on that side.[‡] In a 1 pass–1 pass[§] two-fluid counterflow PHE, the next channel has gaskets covering the ports just opposite the preceding plate (see, e.g., Fig. 1.17*b*, in which now, fluid 2 can flow and fluid 1 cannot flow). Incidentally, each plate has gaskets on only one side, and they sit in grooves on the back side of the neighboring plate. In Fig. 1.16, each fluid makes a single pass through the exchanger because of alternate gasketed and ungasketed ports in each corner opening. The most conventional flow arrangement is 1 pass–1 pass counterflow, with all inlet and outlet connections on the fixed end cover. By blocking flow through some ports with proper gasketing, either one or both fluids could have more than one pass. Also, more than one exchanger can be accommodated in a single frame. In cases with more than two simple 1-pass–1-pass heat exchangers, it is necessary to insert one or more intermediate headers or connector plates in the plate pack at appropriate places (see, e.g., Fig. 1.19). In milk pasteurization applications, there are as many as five exchangers or sections to heat, cool, and regenerate heat between raw milk and pasteurized milk.

Typical plate heat exchanger dimensions and performance parameters are given in Table 1.3. Any metal that can be cold-worked is suitable for PHE applications. The most

[†] A channel is a flow passage bounded by two plates and is occupied by one of the fluids. In contrast, a plate separates the two fluids and transfers heat from the hot fluid to the cold fluid.

[‡] Thus with the proper arrangement, gaskets also distribute the fluids between the channels in addition to providing sealing to prevent leakage.

[§] In a plate heat exchanger, a *pass* refers to a group of channels in which the flow is in the same direction for one full length of the exchanger (from top to bottom of the pack; see Fig. 1.65). In an m pass – n pass two-fluid plate heat exchanger, fluid 1 flows through m passes and fluid 2 through n passes.

TABLE 1.2 Gasket Materials Used in Plate Heat Exchangers

Gasket Material	Generic Name	Maximum Operating Temperature (°C)	Applications	Comments
Natural rubber	<i>cis</i> -1,4-polyisoprene	70	Oxygenated solvents, acids, alcohols	
SBR (styrene butadiene)		80	General-purpose aqueous, alkalies, acids, and oxygenated solvents	Has poor fat resistance
Neoprene	<i>trans</i> -1,4-polychloroprene	70	Alcohols, alkalies, acids, aliphatic hydrocarbon solvents	
Nitrile		100–140	Dairy, fruit juices, beverage, pharmaceutical and biochemical applications, oil, gasoline, animal and vegetable oils, alkalies, aliphatic organic solvents	Is resistant to fatty materials; particularly suitable for cream
Butyl (resin cured)		120–150	Alkalies, acids, animal and vegetable oils, aldehydes, ketones, phenols, and some esters	Has poor fat resistance; suitable for UHT milk duties; resists inorganic chemical solutions up to 150°C
Ethylene propylene (EDPM) rubber		140	Alkalies, oxygenated solvents	Unsuitable for fatty liquids
Silicone rubber	Polydimethylsiloxane	140	General low-temperature use, alcohols, sodium hypochlorite	
Fluorinated rubber		175	High-temperature aqueous solutions, mineral oils and gasoline, organic solvents, animal and vegetable oils	
Compressed asbestos fiber		200–260	Organic solvents, high-operating-temperature applications	

common plate materials are stainless steel (AISI 304 or 316) and titanium. Plates made from Incoloy 825, Inconel 625, and Hastelloy C-276 are also available. Nickel, cupronickel, and monel are rarely used. Carbon steel is not used, due to low corrosion resistance for thin plates. Graphite and polymer plates are used with corrosive fluids. The heat transfer surface area per unit volume for plate exchangers ranges from 120 to 660 m²/m³ (37 to 200 ft²/ft³).

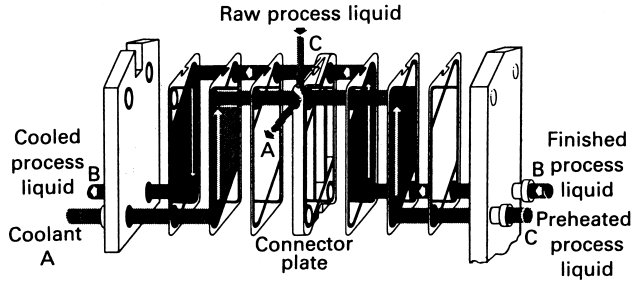

FIGURE 1.19 A three-fluid plate heat exchanger. (Courtesy of Alfa Laval Thermal, Inc., Lund, Sweden.)

Flow Arrangements. A large number of flow arrangements are possible in a plate heat exchanger (shown later in Fig. 1.65), depending on the required heat transfer duty, available pressure drops, minimum and maximum velocities allowed, and the flow rate ratio of the two fluid streams. In each pass there can be an equal or unequal number of thermal plates.[†] Whether the plate exchanger is a single- or multipass unit, whenever possible, the thermodynamically superior counterflow or overall counterflow arrangement (see Sections 1.6.1 and 1.6.2) is used exclusively.

One of the most common flow arrangements in a PHE is a 1-pass–1-pass U configuration (see Fig. 1.65a). This is because this design allows all fluid ports to be located on

TABLE 1.3 Some Geometrical and Operating Condition Characteristics of Plate-and-Frame Heat Exchangers

Unit		Operation	
Maximum surface area	2500 m ²	Pressure	0.1 to 3.0 MPa
Number of plates	3 to 700	Temperature	–40 to 260°C
Port size	Up to 400 mm (for liquids)	Maximum port velocity	6 m/s (for liquids)
		Channel flow rates	0.05 to 12.5 m ³ /h
		Maximum unit flow rate	2500 m ³ /h
Plates		Performance	
Thickness	0.5 to 1.2 mm	Temperature approach	As low as 1°C
Size	0.03 to 3.6 m ²	Heat exchanger efficiency	Up to 93%
Spacing	1.5 to 7 mm	Heat transfer coefficients	3000 to 8000 W/m ² · K
Width	70 to 1200 mm	for water–water duties	
Length	0.4 to 5 m		
Hydraulic diameter	2 to 10 mm		
Surface area per plate	0.02 to 5 m ²		

Source: Data from Shah (1994).

[†] In the plate exchanger, the two outer plates serve as end plates and ideally do not participate in heat transfer between the fluids because of the large thermal resistance associated with thick end plates and air gaps between the end plates and the header/follower. The remaining plates, known as *thermal plates*, transfer heat between the fluids.

the fixed end cover, permitting easy disassembly and cleaning/repair of a PHE without disconnecting any piping. In a multipass arrangement, the ports and fluid connections are located on both fixed and movable end covers. A multipass arrangement is generally used when the flow rates are considerably different or when one would like to use up the available pressure drop by multipassing and hence getting a higher heat transfer coefficient.

Advantages and Limitations. Some advantages of plate heat exchangers are as follows. They can easily be taken apart into their individual components for cleaning, inspection, and maintenance. The heat transfer surface area can readily be changed or rearranged for a different task or for anticipated changing loads, through the flexibility of plate size, corrugation patterns, and pass arrangements. High shear rates and shear stresses, secondary flow, high turbulence, and mixing due to plate corrugation patterns reduce fouling to about 10 to 25% of that of a shell-and-tube exchanger, and enhance heat transfer. Very high heat transfer coefficients are achieved due to the breakup and reattachment of boundary layers, swirl or vortex flow generation, and small hydraulic diameter flow passages. Because of high heat transfer coefficients, reduced fouling, the absence of bypass and leakage streams, and pure counterflow arrangements, the surface area required for a plate exchanger is one-half to one-third that of a shell-and-tube exchanger for a given heat duty, thus reducing the cost, overall volume, and space requirement for the exchanger. Also, the gross weight of a plate exchanger is about one-sixth that of an equivalent shell-and-tube exchanger. Leakage from one fluid to the other cannot take place unless a plate develops a hole. Since the gasket is between the plates, any leakage from the gaskets is to the outside of the exchanger. The residence time (time to travel from the inlet to the outlet of the exchanger) for different fluid particles or flow paths on a given side is approximately the same. This parity is desirable for uniformity of heat treatment in applications such as sterilizing, pasteurizing, and cooking. There are no significant hot or cold spots in the exchanger that could lead to the deterioration of heat-sensitive fluids. The volume of fluid held up in the exchanger is small; this feature is important with expensive fluids, for faster transient response, and for better process control. Finally, high thermal performance can be achieved in plate exchangers. The high degree of counterflow in PHEs makes temperature approaches of up to 1°C (2°F) possible. The high thermal effectiveness (up to about 93%) facilitates economical low-grade heat recovery. The flow-induced vibrations, noise, thermal stresses, and entry impingement problems of shell-and-tube exchangers do not exist for plate heat exchangers.

Some inherent limitations of the plate heat exchangers are caused by plates and gaskets as follows. The plate exchanger is capable of handling up to a maximum pressure of about 3 MPa gauge (435 psig) but is usually operated below 1.0 MPa gauge (150 psig). The gasket materials (except for the PTFE-coated type) restrict the use of PHEs in highly corrosive applications; they also limit the maximum operating temperature to 260°C (500°F) but are usually operated below 150°C (300°F) to avoid the use of expensive gasket materials. Gasket life is sometimes limited. Frequent gasket replacement may be needed in some applications. Pinhole leaks are hard to detect. For equivalent flow velocities, pressure drop in a plate exchanger is very high compared to that of a shell-and-tube exchanger. However, the flow velocities are usually low and plate lengths are “short,” so the resulting pressure drops are generally acceptable. The normal symmetry of PHEs may make phase-change applications[†] more difficult, due to large differences in volumetric flows. For some cases, heat exchanger duties with widely different fluid flow

rates and depending on the allowed pressure drops of the two fluids, an arrangement of a different number of passes for the two fluids may make a PHE advantageous. However, care must be exercised to take full advantage of available pressure drop while multi-passing one or both fluids.

Because of the long gasket periphery, PHEs are not suited for high-vacuum applications. PHEs are not suitable for erosive duties or for fluids containing fibrous materials. In certain cases, suspensions can be handled; but to avoid clogging, the largest suspended particle should be at most one-third the size of the average channel gap. Viscous fluids can be handled, but extremely viscous fluids lead to flow maldistribution problems, especially on cooling. Plate exchangers should not be used for toxic fluids, due to potential gasket leakage. Some of the largest units have a total surface area of about 2500 m² (27,000 ft²) per frame. Some of the limitations of gasketed PHEs have been addressed by the new designs of PHEs described in the next subsection.

Major Applications. Plate heat exchangers were introduced in 1923 for milk pasteurization applications and now find major applications in liquid–liquid (viscosities up to 10 Pa·s) heat transfer duties. They are most common in the dairy, juice, beverage, alcoholic drink, general food processing, and pharmaceutical industries, where their ease of cleaning and the thermal control required for sterilization/pasteurization make them ideal. They are also used in the synthetic rubber industry, paper mills, and in the process heaters, coolers, and closed-circuit cooling systems of large petrochemical and power plants. Here heat rejection to seawater or brackish water is common in many applications, and titanium plates are then used.

Plate heat exchangers are not well suited for lower-density gas-to-gas applications. They are used for condensation or evaporation of non-low-vapor densities. Lower vapor densities limit evaporation to lower outlet vapor fractions. Specially designed plates are now available for condensing as well as evaporation of high-density vapors such as ammonia, propylene, and other common refrigerants, as well as for combined evaporation/condensation duties, also at fairly low vapor densities.

1.5.2.2 Welded and Other Plate Heat Exchangers. One of the limitations of the gasketed plate heat exchanger is the presence of gaskets, which restricts their use to compatible fluids (noncorrosive fluids) and which limits operating temperatures and pressures. To overcome this limitation, a number of welded plate heat exchanger designs have surfaced with welded pairs of plates on one or both fluid sides. To reduce the effective welding cost, the plate size for this exchanger is usually larger than that of the gasketed PHE. The disadvantage of such a design is the loss of disassembling flexibility on the fluid sides where the welding is done. Essentially, laser welding is done around the complete circumference, where the gasket is normally placed. Welding on both sides then results in higher limits on operating temperatures and pressures [350°C (660°F) and 4.0 MPa (580 psig)] and allows the use of corrosive fluids compatible with the plate material. Welded PHEs can accommodate multiple passes and more than two fluid streams. A *Platular heat exchanger* can accommodate four fluid streams. Figure 1.20 shows a pack of plates for a conventional plate-and-frame exchanger, but welded on one

† Special plate designs have been developed for phase-change applications.

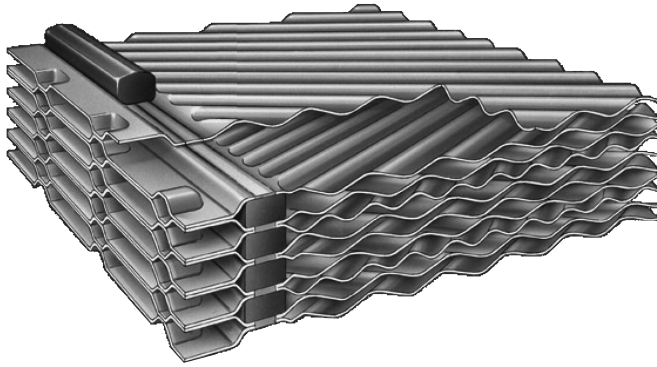

FIGURE 1.20 Section of a welded plate heat exchanger. (Courtesy of Alfa Laval Thermal, Inc., Richmond, VA.)

fluid side. Materials used for welded PHEs are stainless steel, Hastelloy, nickel-based alloys, and copper and titanium.

A *Bavex welded-plate heat exchanger* with welded headers is shown in Fig. 1.21. A *Stacked Plate Heat Exchanger* is another welded plate heat exchanger design (from Packinox), in which rectangular plates are stacked and welded at the edges. The physical size limitations of PHEs [1.2 m wide \times 4 m long maximum (4 \times 13 ft)] are considerably extended to 1.5 m wide \times 20 m long (5 \times 66 ft) in Packinox exchangers. A maximum surface area of over 10,000 m² (100,000 ft²) can be accommodated in one unit. The potential maximum operating temperature is 815°C (1500°F) with an operating pressure of up to 20 MPa (3000 psig) when the stacked plate assembly is placed in a cylindrical pressure vessel. For inlet pressures below 2 MPa (300 psig) and inlet temperatures below 200°C (400°F), the plate bundle is not placed in a pressure vessel but is bolted between two heavy plates. Some applications of this exchanger are for catalytic reforming, hydro-sulfurization, and crude distillation, and in a synthesis converter feed effluent exchanger for methanol and for a propane condenser.

A *vacuum brazed plate heat exchanger* is a compact PHE for high-temperature and high-pressure duties, and it does not have gaskets, tightening bolts, frame, or carrying and guide bars. It consists simply of stainless steel plates and two end plates, all generally copper brazed, but nickel brazed for ammonia units. The plate size is generally limited to 0.3 m². Such a unit can be mounted directly on piping without brackets and foundations. Since this exchanger cannot be opened, applications are limited to negligible fouling cases. The applications include water-cooled evaporators and condensers in the refrigeration industry, and process water heating and heat recovery.

A number of other plate heat exchanger constructions have been developed to address some of the limitations of the conventional PHEs. A double-wall PHE is used to avoid mixing of the two fluids. A wide-gap PHE is used for fluids having a high fiber content or coarse particles/slurries. A graphite PHE is used for highly corrosive fluids. A flow-flex exchanger has plain fins on one side between plates and the other side has conventional plate channels, and is used to handle asymmetric duties (a flow rate ratio of 2:1 and higher). A PHE evaporator has an asymmetric plate design to handle mixed process flows (liquid and vapors) and different flow ratios.

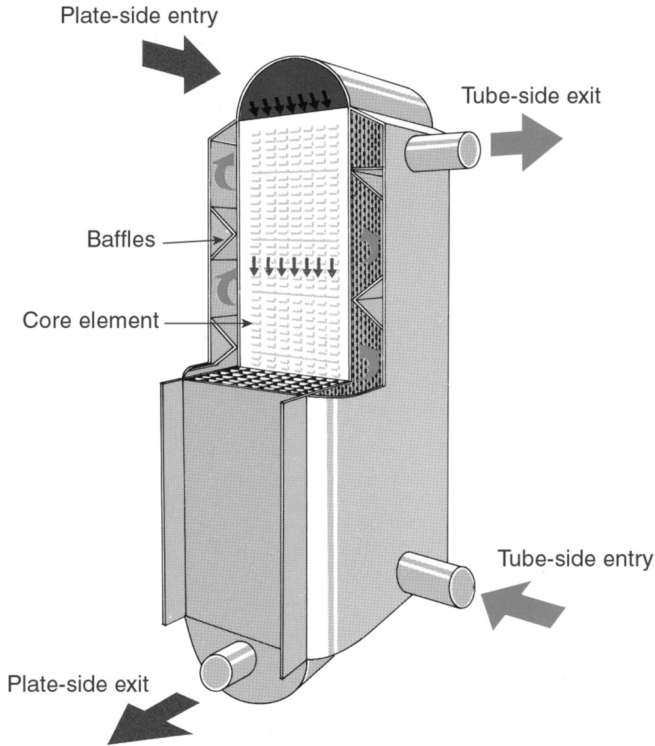

FIGURE 1.21 Bavex welded-plate heat exchanger (From Reay, 1999).

1.5.2.3 Spiral Plate Heat Exchangers. A spiral plate heat exchanger consists of two relatively long strips of sheet metal, normally provided with welded studs for plate spacing, wrapped helically around a split mandrel to form a pair of spiral channels for two fluids, as shown in Fig. 1.22. Alternate passage edges are closed. Thus, each fluid has a long single passage arranged in a compact package. To complete the exchanger, covers are fitted at each end. Any metal that can be cold-formed and welded can be used for this exchanger. Common metals used are carbon steel and stainless steel. Other metals include titanium, Hastelloy, Incoloy, and high-nickel alloys. The basic spiral element is sealed either by welding at each side of the channel or by providing a gasket (non-asbestos based) at each end cover to obtain the following alternative arrangements of the two fluids: (1) both fluids in spiral counterflow; (2) one fluid in spiral flow, the other in crossflow across the spiral; or (3) one fluid in spiral flow, the other in a combination of crossflow and spiral flow. The entire assembly is housed in a cylindrical shell enclosed by two (or only one or no) circular end covers (depending on the flow arrangements above), either flat or conical. Carbon steel and stainless steel are common materials. Other materials used include titanium, Hastelloy, and Incoloy.

A spiral plate exchanger has a relatively large diameter because of the spiral turns. The largest exchanger has a maximum surface area of about 500 m^2 (5400 ft^2) for a maximum shell diameter of 1.8 m (72 in.). The typical passage height is 5 to 25 mm (0.20 to 1.00 in.) and the sheet metal thickness range is 1.8 to 4 mm (0.07 to 0.16 in.).

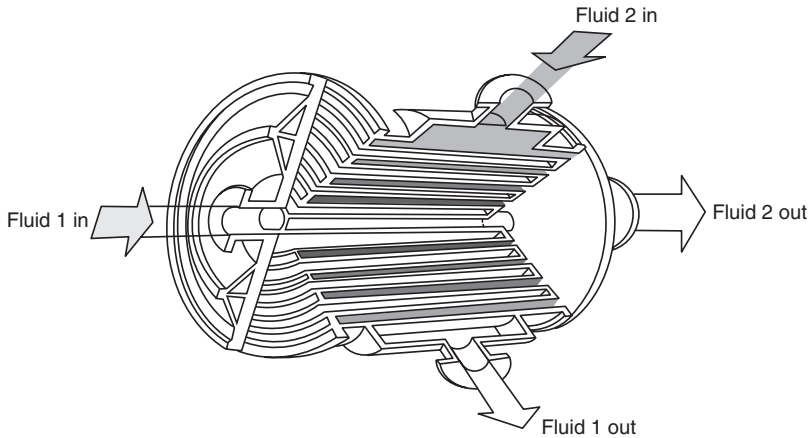

FIGURE 1.22 Spiral plate heat exchanger with both fluids in spiral counterflow.

The heat transfer coefficients are not as high as in a plate exchanger if the plates are not corrugated. However, the heat transfer coefficient is higher than that for a shell-and-tube exchanger because of the curved rectangular passages. Hence, the surface area requirement is about 20% lower than that for a shell-and-tube unit for the same heat duty.

The counterflow spiral unit is used for liquid-liquid, condensing, or gas cooling applications. When there is a pressure drop constraint on one side, such as with gas flows or with high liquid flows, crossflow (straight flow) is used on that side. For condensation or vaporization applications, the unit is mounted vertically. Horizontal units are used when high concentrations of solids exist in the fluid.

The advantages of this exchanger are as follows: It can handle viscous, fouling liquids and slurries more readily because of a *single passage*. If the passage starts fouling, the localized velocity in the passage increases. The fouling rate then decreases with increased fluid velocity. The fouling rate is very low compared to that of a shell-and-tube unit. It is more amenable to chemical, flush, and reversing fluid cleaning techniques because of the single passage. Mechanical cleaning is also possible with removal of the end covers. Thus, maintenance is less than with a shell-and-tube unit. No insulation is used outside the exchanger because of the cold fluid flowing in the outermost passage, resulting in negligible heat loss, if any, due to its inlet temperature closer to surrounding temperature. The internal void volume is lower (less than 60%) than in a shell-and-tube exchanger, and thus it is a relatively compact unit. By adjusting different channel heights, considerable differences in volumetric flow rates of two streams can be accommodated.

The disadvantages of this exchanger are as follows: As noted above, the maximum size is limited. The maximum operating pressure ranges from 0.6 to 2.5 MPa gauge (90 to 370 psig) for large units. The maximum operating temperature is limited to 500°C (930°F) with compressed asbestos gaskets, but most are designed to operate at 200°C (392°F). Field repair is difficult due to construction features.

This exchanger is well suited as a condenser or reboiler. It is used in the cellulose industry for cleaning relief vapors in sulfate and sulfite mills, and is also used as a thermosiphon or kettle reboiler. It is preferred especially for applications having very viscous liquids, dense slurries, digested sewage sludge, and contaminated industrial effluents. A spiral version free of welded studs for plate spacing on one or both fluid sides but

with reduced width is used for sludge and other heavily fouling fluids. It is also used in the treatment of bauxite suspensions and mash liquors in the alcohol industry.

1.5.2.4 Lamella Heat Exchangers. A lamella heat exchanger consists of an outer tubular shell surrounding an inside bundle of heat transfer elements. These elements, referred to as *lamellas*, are flat tubes (pairs of thin dimpled plates, edge welded, resulting in high-aspect-ratio rectangular channels), shown in Fig. 1.23. The inside opening of the lamella ranges from 3 to 10 mm (0.1 to 0.4 in.) and the wall thickness from 1.5 to 2 mm (0.06 to 0.08 in.). Lamellas are stacked close to each other to form narrow channels on the shell side. Lamellas are inserted in the end fittings with gaskets to prevent the leakage from shell to tube side, or vice versa. In a small exchanger, lamellas are of increasing width from either end to the center of the shell to fully utilize the available space, as shown in Fig. 1.23*a*. However, in a larger exchanger, lamellas consist of two (see Fig. 1.23*b*) or more flat tubes to contain operating pressures. There are no baffles. One end of the tube bundle is fixed and the other is floating, to allow for thermal

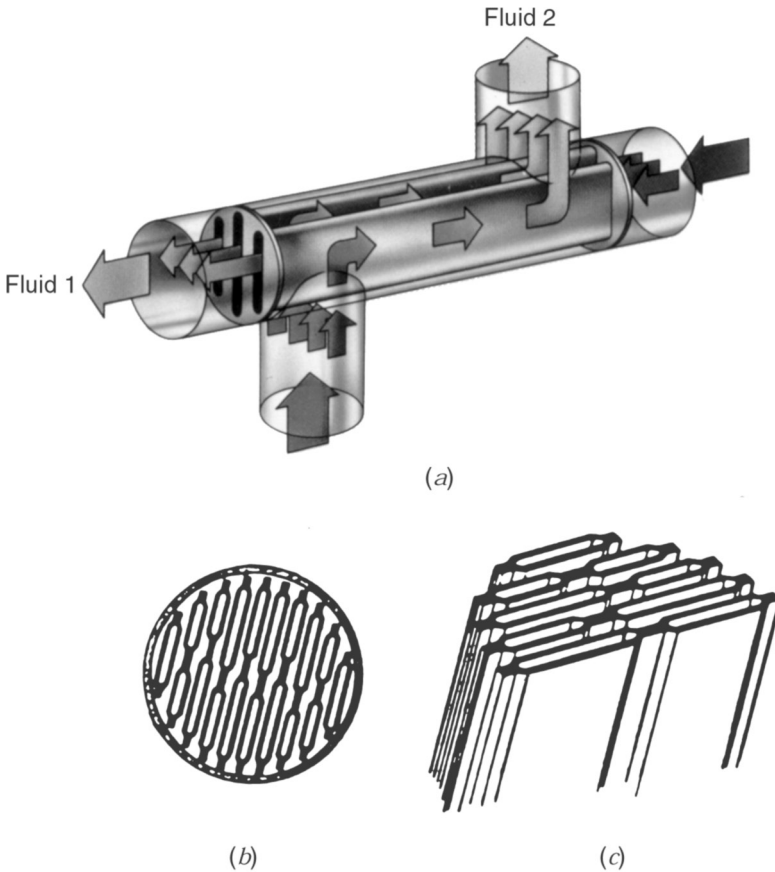

FIGURE 1.23 (a) Lamella heat exchanger; (b) cross section of a lamella heat exchanger; (c) lamellas. (Courtesy of Alfa Laval Thermal, Inc., Lund, Sweden.)

expansion. Thus, this exchanger is a modified floating-head shell-and-tube exchanger. One fluid (tube fluid) flows inside the lamellas and the other fluid (shell fluid) flows longitudinally in the spaces between them, with no baffles on the shell side. The exchanger thus has a single pass, and the flow arrangement is generally counterflow. The flat tube walls have dimples where neighboring tubes are spot-welded. High-heat-transfer coefficients are usually obtained because of small hydraulic diameters and no leakage or bypass streams as encountered in a conventional shell-and-tube exchanger. Also, possible point dimples increase the heat transfer coefficient and pressure drop in the same way as do corrugated plate channels. It can handle fibrous fluids and slurries with proper plate spacing. The large units have surface areas up to 1000 m^2 ($10,800 \text{ ft}^2$). A lamella exchanger weighs less than a shell-and-tube exchanger having the same duty. A lamella exchanger is capable of pressures up to 3.45 MPa gauge (500 psig) and temperature limits of 200°C (430°F) for PTFE gaskets and 500°C (930°F) for nonasbestos gaskets. This exchanger is used for heat recovery in the pulp and paper industry, chemical process industry, and for other industrial applications, in competition with the shell-and-tube exchanger.

1.5.2.5 Printed-Circuit Heat Exchangers. This exchanger shown in Fig. 1.24 has only primary heat transfer surface, as do PHEs. Fine grooves are made in the plate by using

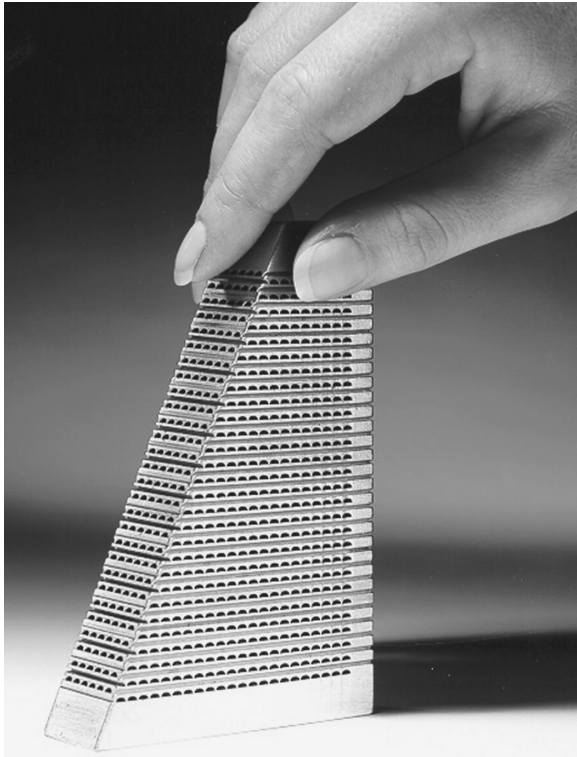

FIGURE 1.24 Printed-circuit crossflow exchanger. (Courtesy of Heatric Division of Meggitt (UK) Ltd., Dorset, UK.)

the same techniques as those employed for making printed circuit boards. A block (stack) of chemically etched plates is then diffusion bonded, and fluid inlet/outlet headers are welded to make the exchanger. For the two fluid streams, there are different etching patterns, as desired to make a crossflow, counterflow, or multipass cross-counterflow exchanger. Multiple passes and multiple fluid streams can be made in a single block. Several blocks are welded together for large heat duty applications. The channel depth is 0.1 to 2 mm (0.004 to 0.08 in.). High surface area densities, 650 to 1300 m²/m³ (200 to 400 ft²/ft³), are achievable for operating pressures 50 to 10 MPa (7250 to 290 psi),[†] and temperatures 150 to 800°C (300 to 1500°F). A variety of materials, including stainless steel, titanium, copper, nickel, and nickel alloys, can be used. It has been used successfully with relatively clean gases, liquids, and phase-change fluids in the chemical processing, fuel processing, waste heat recovery, power and energy, refrigeration, and air separation industries. They are used extensively in offshore oil platforms as compressor aftercoolers, gas coolers, cryogenic processes to remove inert gases, and so on. Having a small channel size, the fluid pressure drop can be a constraint for low-to-moderate pressure applications. However, the main advantage of this exchanger is high pressure/strength, flexibility in design, and high effectivenesses.

1.5.2.6 Panelcoil Heat Exchangers. The basic elements of this exchanger are called panelcoils, platecoils, or embossed-panel coils, as shown in Fig. 1.25. The panelcoil serves as a heat sink or a heat source, depending on whether the fluid within the coil is being cooled or heated. As a result, the shape and size of the panelcoil is made to fit the system, or flat panelcoils are immersed in a tank or placed in the atmosphere for heat transfer. Basically, three different methods have been employed to manufacture panelcoils: a die-stamping process, spot-weld process, and roll-bond process. In the die-stamping process, flow channels are die-stamped on either one or two metal sheets. When one sheet is embossed and joined to a flat (unembossed sheet), it forms a one-sided embossed panelcoil. When both sheets are stamped, it forms a double-sided embossed panelcoil. The two plates are joined by electric resistance welding of the metal sheets. Examples are shown in Fig. 1.25*a* and *b*.

In the spot-weld process, two flat sheets are spot-welded in a desired pattern (no die stamping), and then are inflated by a fluid under high pressure to form flow passages interconnected by weld points. An example is shown in Fig. 1.25*d*.

In a roll-bond process, two sheets of metal (copper or aluminum) are bonded with a true metallurgical bond, except in certain desired “specified channels,” where a special stopweld material is applied. On one of the metal sheets, the stopweld material is applied in the desired flow pattern. This sheet is then stacked with another plain sheet without stopweld material on it. The sheets are then heated and immediately hot-rolled under high pressure to provide a metallurgical bond. Subsequent cold rolling follows to provide an appropriate increase in length. After annealing the panelcoil, a needle is inserted at the edge, exposing stopweld material, and high-pressure air inflates the desired flow passages when the panelcoil is placed between two plates in a heavy hydraulic press. The roll-bond process limits the panelcoils to a flat in shape.

The most commonly used materials for panelcoils are carbon steel, stainless steel, titanium, nickel and its alloys, and monel. The panelcoil sheet metal gauges range between 1.5 and 3.0 mm (0.06 to 0.12 in.) depending on the materials used and whether

[†] Note that operating pressures for 650- and 1300-m²/m³ surface area densities are 50 and 10 MPa, respectively.

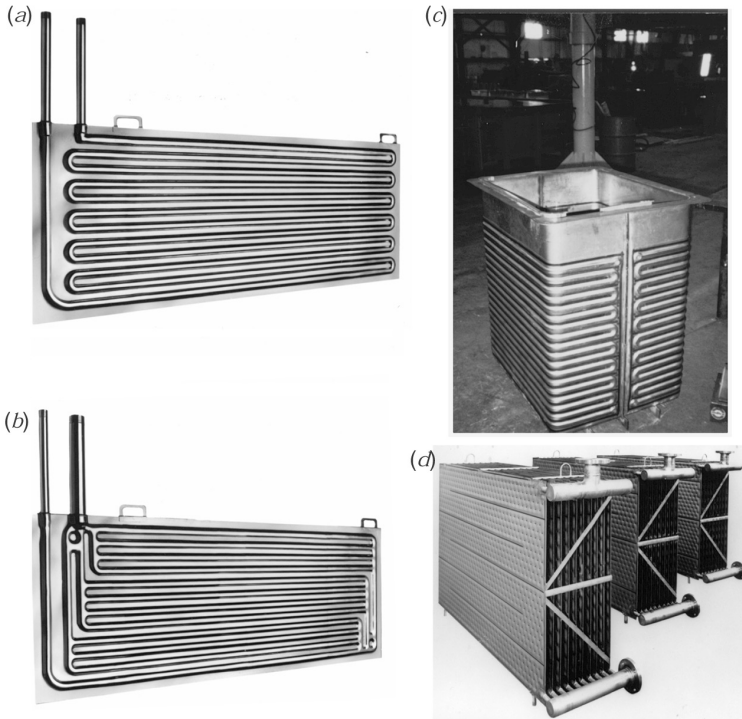

FIGURE 1.25 Die-stamped plate coils: (a) serpentine, (b) multizone, (c) a vessel; (d) spot-welded Econocoil bank. (Courtesy of Tranter PHE, Inc., Wichita, TX.)

or not the panels are single or double embossed. The maximum operating pressure ranges from 1.8 MPa (260 psig) for double-embossed and 1.2 MPa (175 psig) for single-embossed carbon steel, stainless steel, and monel panelcoils to 0.7 MPa (100 psig) for double-embossed titanium panelcoils.

Panelcoil heat exchangers are relatively inexpensive and can be made into desired shapes and thicknesses for heat sinks and heat sources under varied operating conditions. Hence, they have been used in many industrial applications, such as cryogenics, chemicals, fibers, food, paints, pharmaceuticals, and solar absorbers.

1.5.3 Extended Surface Heat Exchangers

The tubular and plate-type exchangers described previously are all prime surface heat exchangers, except for a shell-and-tube exchanger with low finned tubing. Their heat exchanger effectiveness (see Section 3.3.1 for the definition) is usually 60% or below, and the heat transfer surface area density is usually less than $700 \text{ m}^2/\text{m}^3$ ($213 \text{ ft}^2/\text{ft}^3$). In some applications, much higher (up to about 98%) exchanger effectiveness is essential, and the box volume and mass are limited so that a much more compact surface is mandated. Also, in a heat exchanger with gases or some liquids, the heat transfer coefficient is quite low on one or both fluid sides. This results in a large heat transfer surface area requirement. One of the most common methods to increase the surface area and exchanger

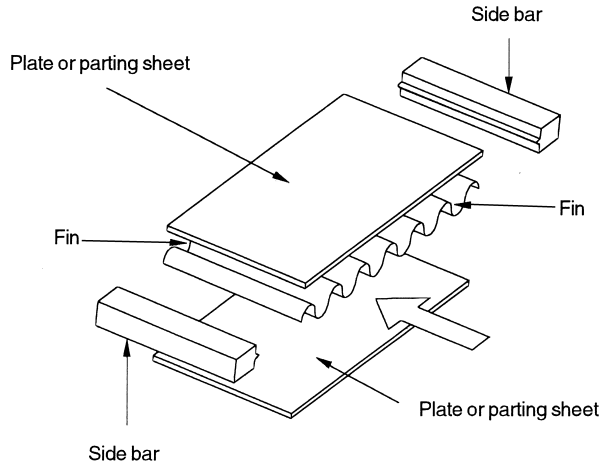

FIGURE 1.26 Basic components of a plate-fin heat exchanger (Shah and Webb, 1983).

compactness is to add the extended surface (fins) and use fins with the *fin density* (*fin frequency*, fins/m or fins/in.) as high as possible on one or both fluid sides, depending on the design requirement. Addition of fins can increase the surface area by 5 to 12 times the primary surface area in general, depending on the design. The resulting exchanger is referred to as an *extended surface exchanger*. Flow area is increased by the use of thin-gauge material and sizing the core properly. The heat transfer coefficient on extended surfaces may be *higher* or *lower* than that on unfinned surfaces. For example, interrupted (strip, louver, etc.) fins provide both an increased area and increased heat transfer coefficient, while internal fins in a tube increase the tube-side surface area but may result in a slight reduction in the heat transfer coefficient, depending on the fin spacing. Generally, increasing the fin density reduces the heat transfer coefficient associated with fins. Flow interruptions (as in offset strip fins, louvered fins, etc.) may increase the heat transfer coefficient two to four times that for the corresponding plain (uncut) fin surface. Plate-fin and tube-fin geometries are the two most common types of extended surface heat exchangers.[†]

1.5.3.1 Plate-Fin Heat Exchangers. This type of exchanger has corrugated fins (most commonly having triangular and rectangular cross sections) or spacers sandwiched between parallel plates (referred to as plates or parting sheets), as shown in Fig. 1.26. Sometimes fins are incorporated in a flat tube with rounded corners (referred to as a *formed tube*), thus eliminating the need for side bars. If liquid or phase-change fluid flows on the other side, the parting sheet is usually replaced by a flat tube with or without inserts or webs (Fig. 1.27). Other plate-fin constructions include drawn-cup

[†] If the heat transfer surface in a prime surface heat exchanger is rough (due either to the manufacturing process or made artificially) or small-scale fins (the fin height is approximately 5% or less of the tube radius) are made integral to the prime surface, the exchanger is sometimes referred to as a *microfin heat exchanger*.

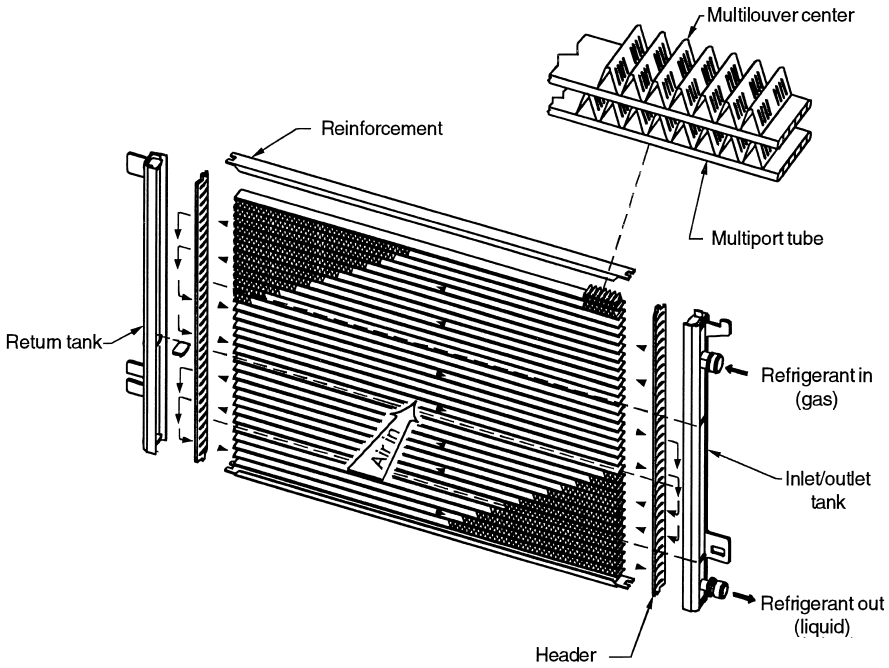

FIGURE 1.27 Flat webbed tube and multilouver fin automotive condenser. (Courtesy of Delphi Harrison Thermal Systems, Lockport, NY.)

(Fig. 1.28) and tube-and-center[†] configurations. The plates or flat tubes separate the two fluid streams, and the fins form the individual flow passages. Alternate fluid passages are connected in parallel by suitable headers to form the two or more fluid sides of the exchanger. Fins are die or roll formed and are attached to the plates by brazing,[‡] soldering, adhesive bonding, welding, mechanical fit, or extrusion. Fins may be used on both sides in gas-to-gas heat exchangers. In gas-to-liquid applications, fins are generally used only on the gas side; if employed on the liquid side, they are used primarily for structural strength and flow-mixing purposes. Fins are also sometimes used for pressure containment and rigidity. In Europe, a plate-fin exchanger is also referred to as a *matrix heat exchanger*.

Plate fins are categorized as (1) plain (i.e., uncut) and straight fins, such as plain triangular and rectangular fins, (2) plain but wavy fins (wavy in the main fluid flow direction), and (3) interrupted fins, such as offset strip, louver, perforated, and pin fins. Examples of commonly used fins are shown in Fig. 1.29. Louver form of the multilouver fin is shown in Fig. 7.29, along with a sketch of its louver form at section AA in

[†] In the automotive industry, corrugated fins in the plate-fin unit are referred to as *centers*, to distinguish them from the flat fins outside the tubes in a tube-fin exchanger. The latter are referred to simply as *fins* in the automotive industry.

[‡] In the automotive industry, the most common brazing technique is controlled atmosphere brazing (CAB; brazing at atmospheric pressure in a nitrogen environment and with noncorrosive flux; also known as a Nocolok process), and sometimes vacuum brazing is used. In the cryogenics industry, only vacuum brazing is used.

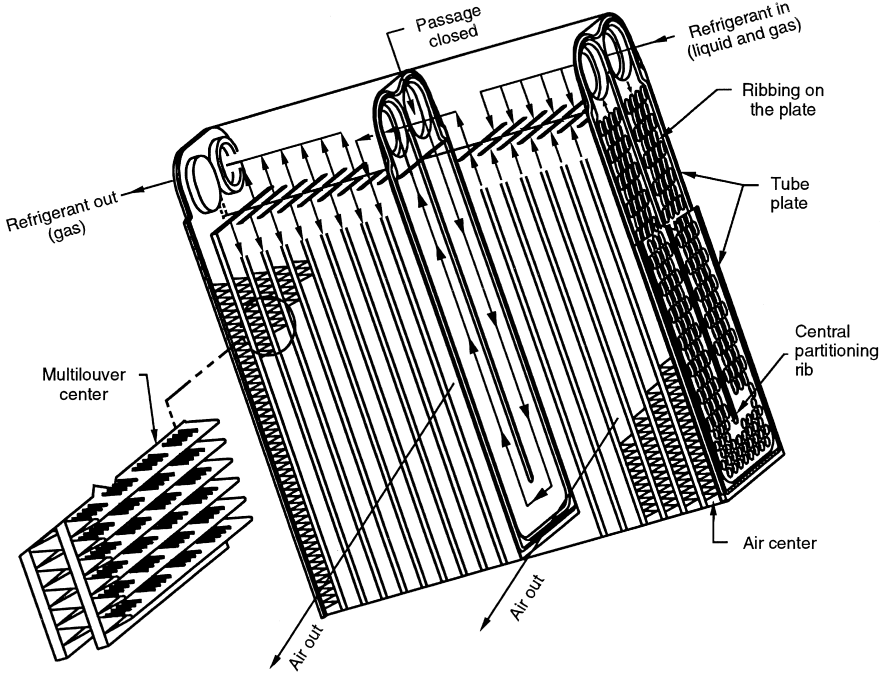

FIGURE 1.28 U-channel ribbed plates and multilouver fin automotive evaporator. (Courtesy of Delphi Harrison Thermal Systems, Lockport, NY.)

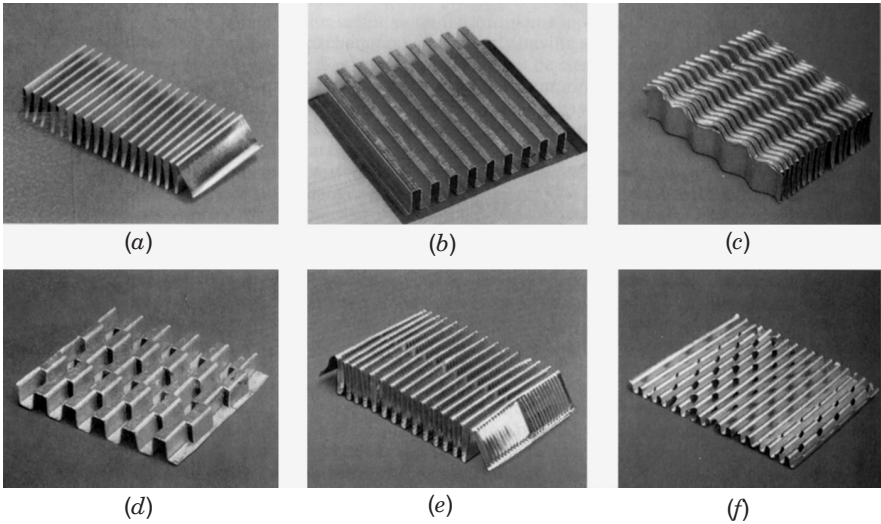

FIGURE 1.29 Corrugated fin geometries for plate-fin heat exchangers: (a) plain triangular fin; (b) plain rectangular fin; (c) wavy fin; (d) offset strip fin; (e) multilouver fin; (f) perforated fin. (Courtesy of Delphi Harrison Thermal Systems, Lockport, NY.)

Fig. 7.29c. Strip fins are also referred to as *offset fins*, *lance-offset fins*, *serrated fins*, and *segmented fins*. Many variations of interrupted fins are used in industry since they employ the materials of construction more efficiently than do plain fins and are therefore used when allowed by the design constraints.

Plate-fin exchangers are generally designed for moderate operating pressures [less than about 700 kPa gauge (100 psig)], although plate-fin exchangers are available commercially for operating pressures up to about 8300 kPa gauge (1200 psig). Recently, a condenser for an automotive air-conditioning system (see Fig. 1.27) using carbon dioxide as the working fluid has been developed for operating pressures of 14 MPa (2100 psia). A recently developed titanium plate-fin exchanger (manufactured by superelastic deformation and diffusion bonding, shown in Fig. 1.30) can take 35 MPa (5000 psig) and higher pressures. The temperature limitation for plate-fin exchangers depends on the method of bonding and the materials employed. Such exchangers have been made from metals for temperatures up to about 840°C (1550°F) and made from ceramic materials for temperatures up to about 1150°C (2100°F) with a peak temperature of 1370°C (2500°F). For ventilation applications (i.e., preheating or precooling of incoming air to a building/room), the plate-fin exchanger is made using Japanese treated (hygroscopic) paper and has the operating temperature limit of 50°C (122°F). Thus,

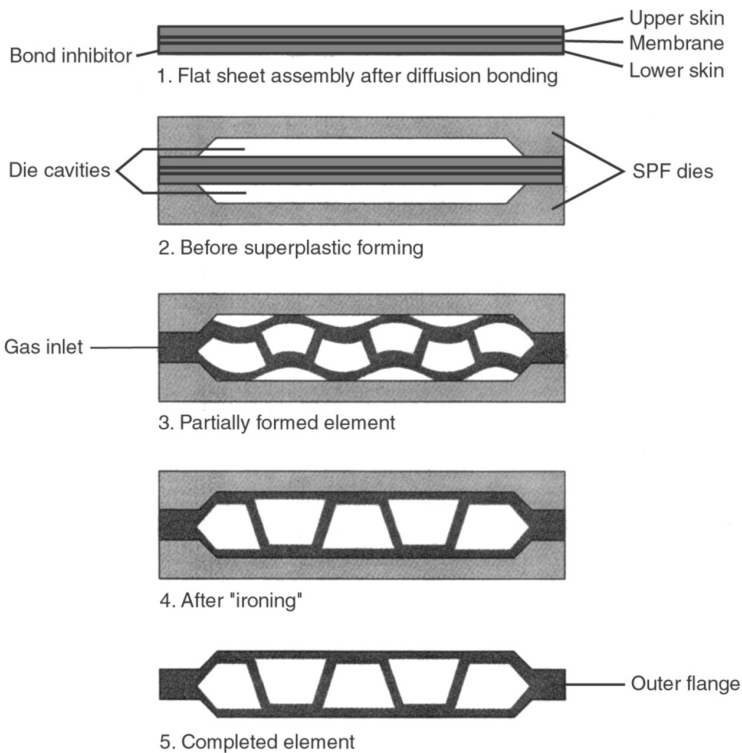

FIGURE 1.30 Process of manufacturing of a super elastically deformed diffusion bonded plate-fin exchanger (From Reay, 1999).

plates and fins are made from a variety of materials, metals, ceramics, and papers. Plate-fin exchangers have been built with a surface area density of up to $5900 \text{ m}^2/\text{m}^3$ ($1800 \text{ ft}^2/\text{ft}^3$). There is total freedom in selecting the fin surface area on each fluid side, as required by the design, by varying the fin height and fin density. Although typical fin densities are 120 to 700 fins/m (3 to 18 fins/in.), applications exist for as many as 2100 fins/m (53 fins/in.). Common fin thickness ranges between 0.05 and 0.25 mm (0.002 to 0.01 in.). Fin heights may range from 2 to 25 mm (0.08 to 1.0 in.). A plate-fin exchanger with 600 fins/m (15.2 fins/in.) provides about 1300 m^2 ($400 \text{ ft}^2/\text{ft}^3$) of heat transfer surface area per cubic meter of volume occupied by the fins. Plate-fin exchangers are manufactured in virtually all shapes and sizes and are made from a variety of materials. A cryogenic plate-fin exchanger has about 10% of the volume of an equivalent shell-and-tube exchanger (Reay, 1999).

Plate-fin exchangers have been produced since the 1910s in the auto industry (copper fin–brass tubes), since the 1940s in the aerospace industry (using aluminum), and in gas liquefaction applications since the 1950s using aluminum because of the better mechanical characteristics of aluminum at low temperatures. They are now used widely in electric power plants (gas turbine, steam, nuclear, fuel cell, etc.), propulsive power plants (automobile, truck, airplane, etc.), systems with thermodynamic cycles (heat pump, refrigeration, etc.), and in electronic, cryogenic, gas-liquefaction, air-conditioning, and waste heat recovery systems.

1.5.3.2 Tube-Fin Heat Exchangers. These exchangers may be classified as conventional and specialized tube-fin exchangers. In a conventional tube-fin exchanger, heat transfer between the two fluids takes place by conduction through the tube wall. However, in a heat pipe exchanger (a specialized type of tube-fin exchanger), tubes with both ends closed act as a separating wall, and heat transfer between the two fluids takes place through this “separating wall” (heat pipe) by conduction, and evaporation and condensation of the heat pipe fluid. Let us first describe conventional tube-fin exchangers and then heat pipe exchangers.

Conventional Tube-Fin Exchangers. In a gas-to-liquid exchanger, the heat transfer coefficient on the liquid side is generally one order of magnitude higher than that on the gas side. Hence, to have balanced thermal conductances (approximately the same hA) on both sides for a minimum-size heat exchanger, fins are used on the gas side to increase surface area A . This is similar to the case of a condensing or evaporating fluid stream on one side and gas on the other. In addition, if the pressure is high for one fluid, it is generally economical to employ tubes.

In a tube-fin exchanger, round and rectangular tubes are most common, although elliptical tubes are also used. Fins are generally used on the outside, but they may be used on the inside of the tubes in some applications. They are attached to the tubes by a tight mechanical fit, tension winding, adhesive bonding, soldering, brazing, welding, or extrusion.

Depending on the fin type, tube-fin exchangers are categorized as follows: (1) an individually finned tube exchanger or simply a *finned tube exchanger*, as shown in Figs. 1.31*a* and 1.32, having normal fins on individual tubes; (2) a tube-fin exchanger having flat (continuous) fins, as shown in Figs. 1.31*b* and 1.33; the fins can be plain, wavy, or interrupted, and the array of tubes can have tubes of circular, oval, rectangular, or other shapes; and (3) longitudinal fins on individual tubes, as shown in Fig. 1.34. A *tube-fin exchanger with flat fins* has been referred to variously as a *plate-fin and tube*, *plate*

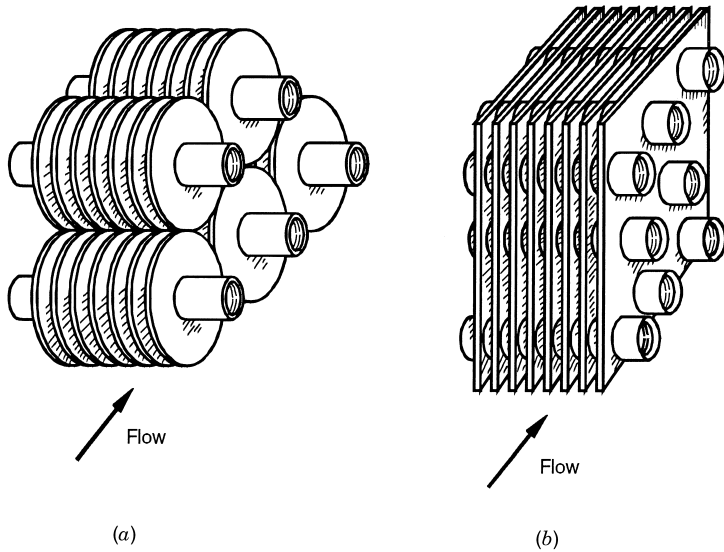

FIGURE 1.31 (a) Individually finned tubes; (b) flat (continuous) fins on an array of tubes. The flat fins are shown as plain fins, but they can be wavy, louvered, or interrupted.

finned tube, and *tube in-plate fin exchanger* in the literature. To avoid confusion with a plate-fin exchanger defined in Section 1.5.3.1, we refer to it as a tube-fin exchanger having flat (plain, wavy, or interrupted) fins. A tube-fin exchanger of the aforementioned categories 1 and 2 is referred to as a *coil* in the air-conditioning and refrigeration industries and has air outside and a refrigerant inside the tube. Individually finned tubes are probably more rugged and practical in large tube-fin exchangers. The exchanger with flat fins is usually less expensive on a unit heat transfer surface area basis because of its simple and mass-production construction features. Longitudinal fins are generally used in condensing applications and for viscous fluids in double-pipe heat exchangers.

Shell-and-tube exchangers sometime employ low finned tubes to increase the surface area on the shell side when the shell-side heat transfer coefficient is low compared to the tube-side coefficient, such as with highly viscous liquids, gases, or condensing refrigerant vapors. The low finned tubes are generally helical or annular fins on individual tubes; the fin outside diameter (see Fig. 1.9) is slightly smaller than the baffle hole. Longitudinal fins on individual tubes are also used in shell-and-tube exchangers. Fins on the inside of the tubes are of two types: integral fins as in internally finned tubes, and attached fins. Internally finned tubes are shown in Fig. 1.35.

Tube-fin exchangers can withstand ultrahigh pressures on the tube side. The highest temperature is again limited by the type of bonding, materials employed, and material thickness. Tube-fin exchangers usually are less compact than plate-fin units. Tube-fin exchangers with an area density of about $3300 \text{ m}^2/\text{m}^3$ ($1000 \text{ ft}^2/\text{ft}^3$) are available commercially. On the fin side, the surface area desired can be achieved through the proper fin density and fin geometry. Typical fin densities for flat fins vary from 250 to 800 fins/m (6 to 20 fins/in.), fin thicknesses vary from 0.08 to 0.25 mm (0.003 to 0.010 in.), and fin flow lengths vary from 25 to 250 mm (1 to 10 in.). A tube-fin exchanger having flat fins with 400 fins/m (10 fins/in.) has a surface area density of about $720 \text{ m}^2/\text{m}^3$ ($220 \text{ ft}^2/\text{ft}^3$).

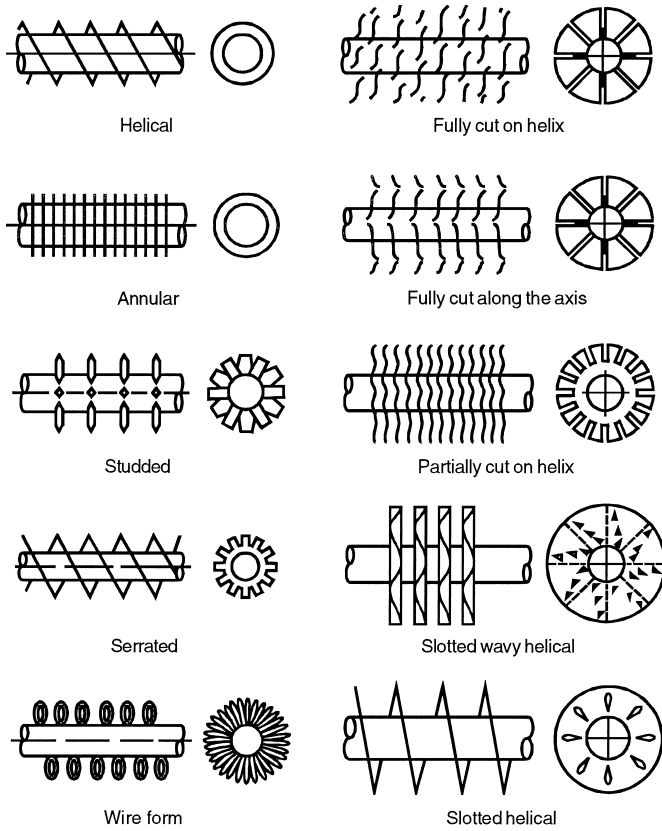

FIGURE 1.32 Individually finned tubes (Shah, 1981).

Tube-fin exchangers are employed when one fluid stream is at a higher pressure and/or has a significantly higher heat transfer coefficient than that of the other fluid stream. As a result, these exchangers are used extensively as condensers and evaporators in air-conditioning and refrigeration applications, as condensers in electric power plants, as oil coolers in propulsive power plants, and as air-cooled exchangers (also referred to as *fin-fan exchangers*) in process and power industries.

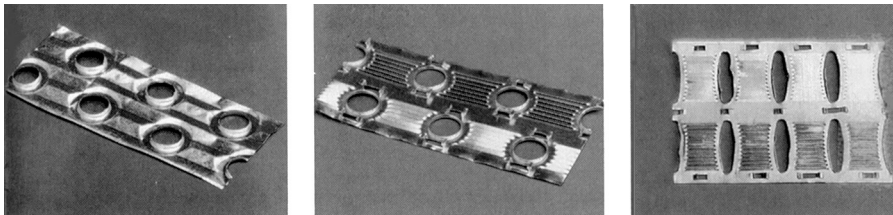

FIGURE 1.33 Flat fins on an array of round, flat, or oval tubes: (a) wavy fin; (b) multilouver fin; both fins with staggered round tubes; (c) multilouver fin with inline elliptical tubes. (Courtesy of Delphi Harrison Thermal Systems, Lockport, NY.)

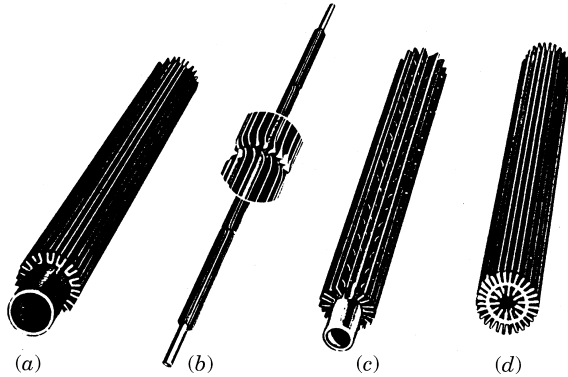

FIGURE 1.34 Longitudinal fins on individual tubes: (a) continuous plain; (b) cut and twisted; (c) perforated; (d) internal and external longitudinal fins. (Courtesy of Brown Fintube Company, Houston, TX.)

An *air-cooled exchanger* is a tube-fin exchanger in which hot process fluids (usually liquids or condensing fluids) flow inside the tubes, and atmospheric air is circulated outside by forced or induced draft over the extended surface. If used in a cooling tower with the process fluid as water, it is referred to as a *dry cooling tower*. Characteristics of this type of exchanger are shallow tube bundles (short airflow length) and large face area, due to the design constraint on the fan power.

Heat Pipe Heat Exchangers. This type of exchanger is similar to a tube-fin exchanger with individually finned tubes or flat (continuous) fins and tubes. However, the tube is a



FIGURE 1.35 Internally finned tubes. (Courtesy of Forged-Fin Division, Noranda Metal Industries, Inc., Newtown, CT.)

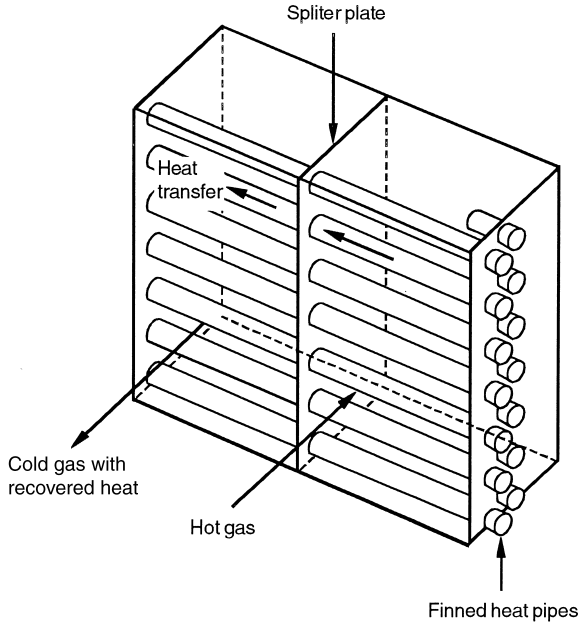

FIGURE 1.36 Heat pipe heat exchanger (Reay, 1979).

heat pipe, and hot and cold gases flow continuously in separate parts of the exchanger, as shown in Fig. 1.36. Heat is transferred from the hot gas to the evaporation section of the heat pipe by convection; the thermal energy is then carried away by the vapor to the condensation section of the heat pipe, where it transfers heat to the cold gas by convection.

As shown in Fig. 1.37, a heat pipe is a closed tube or vessel that has been evacuated, partially filled with a heat transfer fluid (a working fluid sufficient to wet the entire wick),

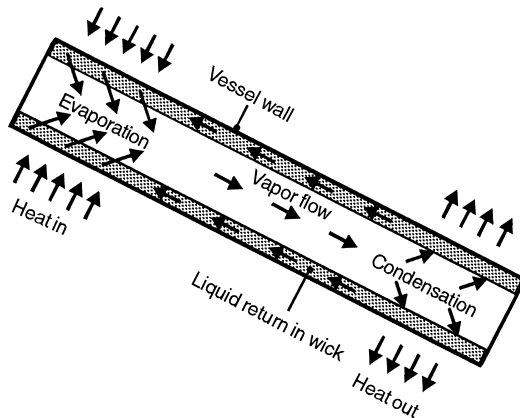

FIGURE 1.37 Heat pipe and its operation.

and sealed permanently at both ends. The inner surfaces of a heat pipe are usually lined with a capillary wick (a porous lining, screen, or internally grooved wall). The wick is what makes the heat pipe unique; it forces condensate to return to the evaporator by the action of capillary force. In a properly designed heat pipe, the wick is saturated with the liquid phase of the working fluid, while the remainder of the tube contains the vapor phase. When heat is applied at the evaporator by an external source, the working fluid in the wick in that section vaporizes, the pressure increases, and vapor flows to the condenser section through the central portion of the tube. The vapor condenses in the condenser section of the pipe, releasing the energy of phase change to a heat sink (to a cold fluid, flowing outside the heat pipe; see Fig. 1.37). The heat applied at the evaporator section tries to dry the wick surface through evaporation, but as the fluid evaporates, the liquid–vapor interface recedes into the wick surface, causing a capillary pressure to be developed. This pressure is responsible for transporting the condensed liquid back to the evaporator section, thereby completing a cycle. Thus, a properly designed heat pipe can transport the energy of phase change continuously from the evaporator to the condenser without drying out the wick. The condensed liquid may also be pumped back to the evaporator section by the capillary force or by the force of gravity if the heat pipe is inclined and the condensation section is above the evaporator section. If the gravity force is sufficient, no wick may be necessary. As long as there is a temperature difference between the hot and cold gases in a heat pipe heat exchanger, the closed-loop evaporation–condensation cycle will be continuous, and the heat pipe will continue functioning. Generally, there is a small temperature difference between the evaporator and condenser section [about 5°C (9°F) or so], and hence the overall thermal resistance of a heat pipe in a heat pipe exchanger is small. Although water is a common heat pipe fluid, other fluids are also used, depending on the operating temperature range.

A heat pipe heat exchanger (HPHE), shown in Fig. 1.36 for a gas-to-gas application, consists of a number of finned heat pipes (similar to an air-cooled condenser coil) mounted in a frame and used in a duct assembly. Fins on the heat pipe increase the surface area to compensate for low heat transfer coefficients with gas flows. The fins can be spirally wrapped around each pipe, or a number of pipes can be expanded into flat plain or augmented fins. The fin density can be varied from side to side, or the pipe may contain no fins at all (liquid applications). The tube bundle may be horizontal or vertical with the evaporator sections below the condenser sections. The tube rows are normally staggered with the number of tube rows typically between 4 and 10. In a gas-to-gas HPHE, the evaporator section of the heat pipe spans the duct carrying the hot exhaust gas, and the condenser section is located in the duct through which the air to be preheated flows. The HPHE has a splitter plate that is used primarily to prevent mixing between the two gas streams, effectively sealing them from one another. Since the splitter plate is thin, a heat pipe in a HPHE does not have the usual adiabatic section that most heat pipes have.

Unit size varies with airflow. Small units have a face size of 0.6 m (length) by 0.3 m (height), and the largest units may have a face size up to 5 m × 3 m. In the case of gas-to-liquid heat exchangers, the gas section remains the same, but because of the higher external heat transfer coefficient on the liquid side, it need not be finned externally or can even be shorter in length.

The heat pipe performance is influenced by the angle of orientation, since gravity plays an important role in aiding or resisting the capillary flow of the condensate. Because of this sensitivity, tilting the exchanger may control the pumping power and ultimately the heat transfer. This feature can be used to regulate the performance of a

heat pipe heat exchanger. For further details on the design of a HPHE, refer to Shah and Giovannelli (1988).

Heat pipe heat exchangers are generally used in gas-to-gas heat transfer applications. They are used primarily in many industrial and consumer product-oriented waste heat recovery applications.

1.5.4 Regenerators

The regenerator is a storage-type heat exchanger, as described earlier. The heat transfer surface or elements are usually referred to as a *matrix* in the regenerator. To have continuous operation, either the matrix must be moved periodically into and out of the fixed streams of gases, as in a *rotary regenerator* (Figs. 1.38 through 1.40), or the gas flows must be diverted through valves to and from the fixed matrices as in a *fixed-matrix regenerator* (Fig. 1.41). The latter is also sometimes referred to as a *periodic-flow regenerator*,[†] a *swing regenerator*, or a *reversible heat accumulator*. Thus, in a rotary

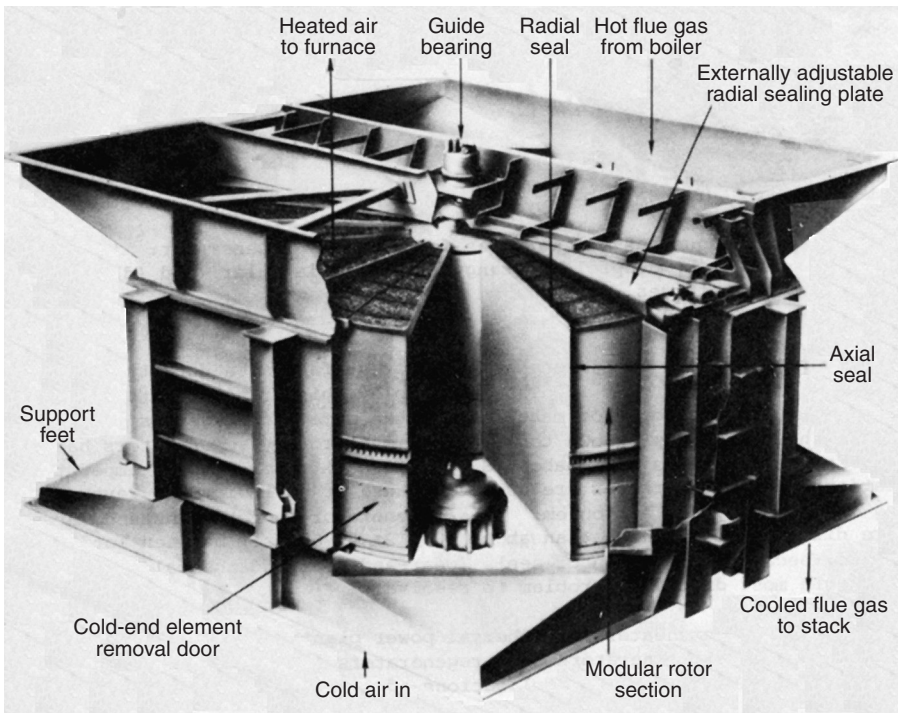

FIGURE 1.38 Ljungstrom air preheater. (Courtesy of ABB Alstom Power Air Preheater, Inc., Wellsville, NY.)

[†] Both rotary matrix and fixed-matrix regenerators have been designated as periodic-flow heat exchangers by Kays and London (1998), because from the viewpoint of an observer riding on the matrix, periodic conditions are experienced in both types of regenerators.

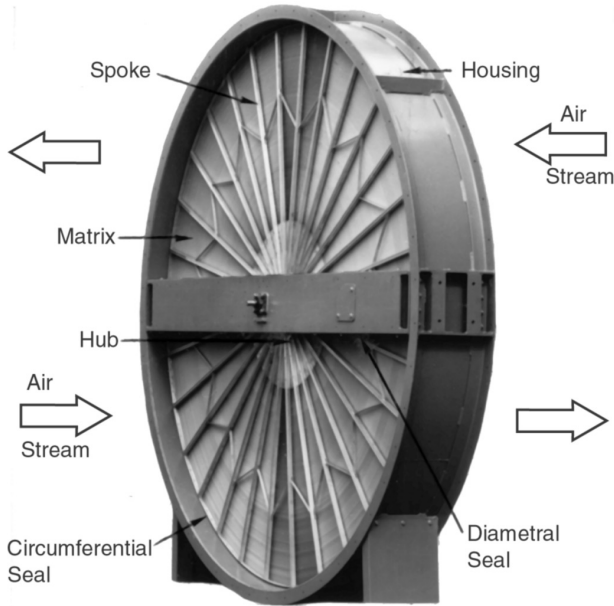

FIGURE 1.39 Heat wheel or a rotary regenerator made from a polyester film.

regenerator, the matrix (disk or rotor) rotates continuously with a constant fraction of the core (having disk sector angle θ_h) in the hot-fluid stream and the remaining fraction (having the disk sector angle θ_c) in the cold-fluid stream; the outlet fluid temperatures vary across the flow area and are independent of time. The two fluids generally flow in the opposite directions and are separated by some form of ductwork and rubbing seals on

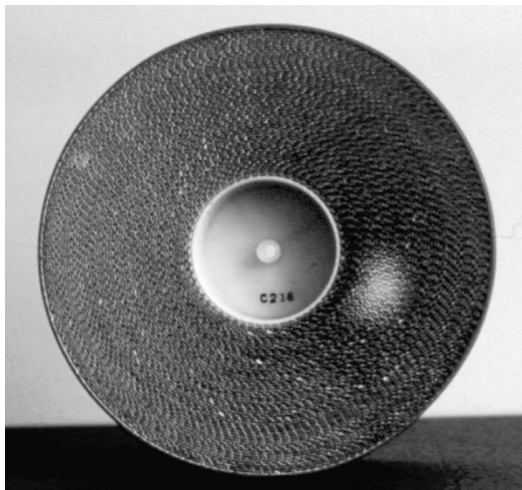

FIGURE 1.40 Rotary regenerator made from a treated Japanese paper.

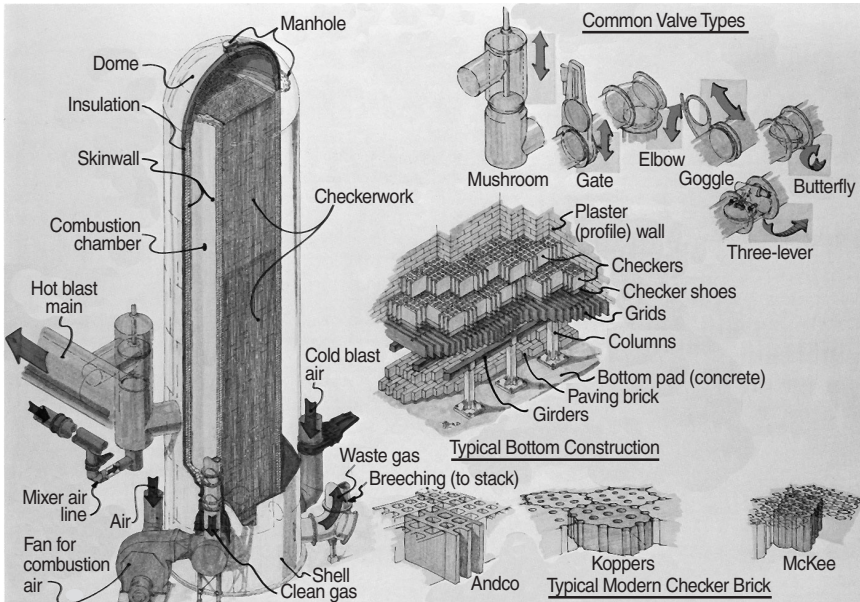

FIGURE 1.41 Cowper stove. (Courtesy of Andco Industries, Inc., Buffalo, NY.)

the matrix. In a fixed-matrix regenerator, the hot and cold fluids are ducted through the use of valves to the different matrices (with a minimum of two identical matrices for continuous operation) of the regenerator in alternate operating periods P_h and P_c ; the outlet fluid temperatures vary with time. Here again, the two fluids alternately flow in opposite directions in a given matrix.

A third type of regenerator has a fixed matrix (in disk form) and fixed streams of gases, but the gases are ducted through rotating hoods (headers) to the matrix as shown in Fig. 1.42. This Rothemuhle regenerator is used as an air preheater in some power-generating plants. Since the basic thermal design theory of all types of regenerators is the same, no specific attention will be given to the Rothemuhle regenerator for the thermal design.

The desired material properties for the regenerator are high volumetric heat capacity (high ρc_p) and low effective thermal conductivity in the longitudinal (gas flow) direction. It should be noted that at very low temperatures, 20 K (36°R) and below, the specific heat of most metals decreases substantially, thus affecting the regenerator performance significantly.

The thermodynamically superior counterflow arrangement is usually employed for storage type heat exchangers by introducing gases successively at the opposite ends. When the rotational speed or frequency of switching hot and cold fluids through such a regenerator is increased, its thermal performance ideally approaches that of a pure counterflow heat exchanger; but in reality, the carryover leakage may become significant with increased speed, thus reducing the regenerator performance. For some applications, a parallelflow arrangement (gases introduced successively at the same end) may be used, but there is no counterpart of the single- or multipass crossflow arrangements common in recuperators. For a rotary regenerator, the design of seals to prevent leakages of hot

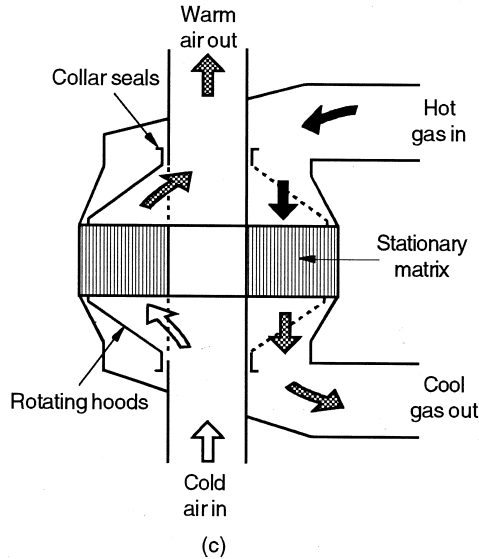

FIGURE 1.42 Rothemuhle regenerator. (Courtesy of Babcock and Wilcox, New Orleans, LA.)

to cold fluids, and vice versa, becomes a difficult task, especially if the two fluids are at significantly different pressures. Rotating drives also pose a challenging mechanical design problem. For a fixed-matrix regenerator operating at high temperatures, due to thermal distortion of housing and valves, various large and small cracks occur in the matrix housing and the valves do not seal the flow of gases perfectly, resulting in pressure leakages.

Major advantages of the regenerators are the following. A much more compact surface may be employed than in a recuperator, thus providing a reduced exchanger volume for given exchanger effectiveness and pressure drop and thereby making a regenerator economical compared to an equivalent recuperator. The major reason for having a much more compact surface for a regenerator is that the hot and cold gas streams are separated by radial seals or valves, unlike in a recuperator, where the primary surface is used to separate the fluid streams. The cost of manufacturing such a compact regenerator surface per unit of heat transfer area is usually substantially lower than that for the equivalent recuperator. Similarly, material cost could be lower in a regenerator than in a recuperator. Hence, a compact regenerator usually has a smaller volume and is lower in weight than an equivalent recuperator. Effectively, many fin configurations of plate-fin exchangers and any finely divided matrix material (high specific heat preferred) that provides high surface area density may be used. However, the leakproof core required in a recuperator is not essential in a regenerator, due to the mode of operation. Regenerators have been made from metals, ceramics, nylon, plastics, and paper, depending on the application. Another important advantage of a counterflow regenerator over a counterflow recuperator is that the design of inlet and outlet headers used to distribute hot and cold gases in the matrix is simple. This is because both fluids flow in different sections (separated by radial seals) of a rotary regenerator, or one fluid enters and leaves

one matrix at a time in a fixed-matrix regenerator. In contrast, the header design to separate two fluids at the inlet and outlet in a counterflow recuperator is complex and costly (see Fig. 1.49 for possible header arrangements). Also, in a rotary regenerator, the flow sectors for the hot and cold gases can be designed to optimize the pressure drop on the hot and cold gases; and the critical pressure drop (usually on the hot side) in a rotary regenerator is lower than that in a comparable recuperator. The matrix surface has self-cleaning characteristics, resulting in low gas-side fouling and associated corrosion, if any, because the hot and cold gases flow alternately in opposite directions in the same fluid passage. Hence, regenerators are used with particulate-laden gases that promote surface fouling in a recuperator. Compact surface area density and the counterflow arrangement make the regenerator ideally suited for gas-to-gas heat exchanger applications requiring high exchanger effectiveness, generally exceeding 85%.

A major disadvantage of a rotary regenerator is that an unavoidable carryover of a small fraction of one fluid stream trapped in the flow passages under the radial seal is pushed out by the other fluid stream just after the periodic flow switching. Similar unavoidable carryover of the fluid stream trapped in the void volume of a given matrix of a fixed-matrix regenerator occurs when it is pushed out by the other fluid stream just after valve switching. Where fluid contamination (small mixing) is prohibited as with liquid flows, a regenerator cannot be used. Hence, regenerators are used exclusively for gas-to-gas heat and/or energy transfer applications, primarily for waste heat recovery applications, and are not used with liquid or phase-changing fluids. Other disadvantages are listed separately in the following subsections for rotary and fixed-matrix regenerators.

1.5.4.1 Rotary Regenerators. Rotary regenerators are shown in Figs. 1.38 through 1.40. Depending on the applications, rotary regenerators are variously referred to as a *heat wheel*, *thermal wheel*, *Munter wheel*, or *Ljungstrom wheel*. When the gas flows are laminar, the rotary regenerator is also referred to as a *laminar flow wheel*.

In this exchanger, any of the plain plate-fin surface geometries could be used in the matrix made up of thin metal sheets. Interrupted passage surfaces (such as strip fins, louver fins) are not used because a transverse (to the main flow direction) flow leakage is present if the two fluids are at different pressures. This leak mixes the two fluids (contaminates the lower pressure fluid) and reduces the exchanger effectiveness. Hence, the matrix generally has continuous (uninterrupted) flow passages. Flat or wavy spacers are used to stack the “fins”[†] (see Fig. 1.43). The fluid is unmixed at any cross section for these surfaces. Two examples of rotary regenerator surfaces are shown in Fig. 1.43. The herringbone or skewed passage matrix does not require spacers for stacking the “fins”. The design Reynolds number range with these types of surfaces is 100 to 1000.

The matrix in the regenerator is rotated by a hub shaft or a peripheral ring gear drive. Every matrix element is passed periodically from the hot to the cold stream and back again. The time required for a complete rotation of the matrix is equivalent to the total period of a fixed-matrix regenerator. In a rotary regenerator, the stationary radial seal locations control the desired frontal areas for each fluid and also serve

[†] It should be emphasized that in a regenerator matrix, however, the entire surface acts as a direct heat-absorbing and heat-releasing surface (a primary surface); there is no secondary surface or fins, although the surface between spacers is usually referred to as fins.

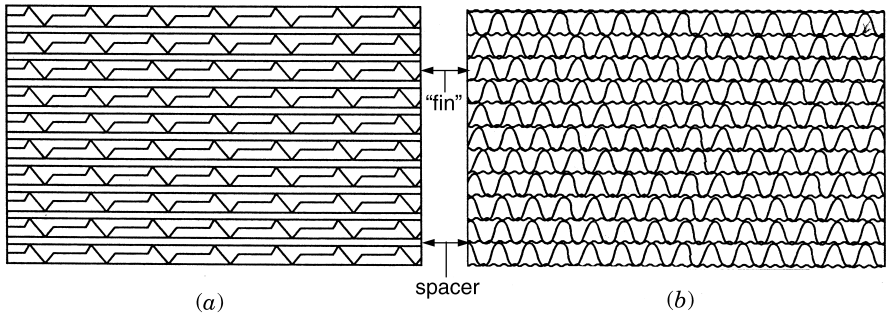

FIGURE 1.43 Continuous-passage matrices for a rotary regenerator: (a) notched plate; (b) triangular passage.

to minimize the primary leakage from the high-pressure fluid to the low-pressure fluid.

A number of seal configurations are used in rotary regenerators. Two common shapes are shown in Fig. 1.44. For the annular sector-shaped seals shown in Fig. 1.44a, flow passages at every radial location experience the same flow exposure and seal-coverage histories. For the uniform-width seals in Fig. 1.44b, flow passages at different radial locations experience different flow exposure and seal coverage. For regenerators with seals of equal area but arbitrary shape, the regenerator effectiveness is highest for annular sector-shaped seals (Beck and Wilson, 1996).

Rotary regenerators have been designed for surface area densities of up to about $6600 \text{ m}^2/\text{m}^3$ ($2000 \text{ ft}^2/\text{ft}^3$). They can employ thinner stock material, resulting in the lowest amount of material for a given effectiveness and pressure drop of any heat exchanger known today. Metal rotary regenerators have been designed for continuous operating inlet temperatures up to about 790°C (1450°F). For higher-temperature applications, ceramic matrices are used. Plastics, paper, and wool are used for regenerators operating below 65°C (150°F). Metal and ceramic regenerators cannot withstand large pressure differences [greater than about 400 kPa (60 psi)] between hot and cold gases, because the design of seals (wear and tear, thermal distortion, and subsequent leakage) is the single most difficult problem to resolve. Plastic, paper, and wool regenerators operate approxi-

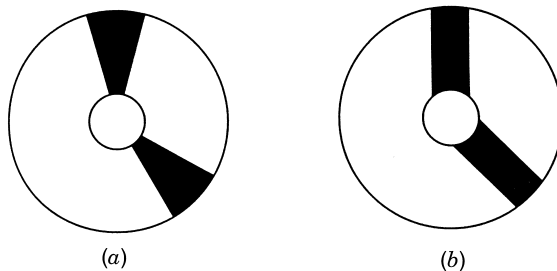

FIGURE 1.44 Seals used in rotary regenerators: (a) annular sector shaped; (b) uniform width shape (Beck and Wilson, 1996).

mately at atmospheric pressure. Seal leakage can reduce the regenerator effectiveness significantly. Rotary regenerators also require a power input to rotate the core from one fluid to the other at the rotational speed desired.

Typical power plant regenerators have a rotor diameter up to 10 m (33 ft) and rotational speeds in the range 0.5 to 3 rpm (rev per min). Air-ventilating regenerators have rotors with diameters of 0.25 to 3 m (0.8 to 9.8 ft) and rotational speeds up to 10 rpm. Vehicular regenerators have diameters up to 0.6 m (24 in.) and rotational speeds up to 18 rpm.

Ljungstrom air preheaters for thermal power plants, commercial and residential oil- and coal-fired furnaces, and regenerators for the vehicular gas turbine power plants are typical examples of metal rotary regenerators for preheating inlet air. Rotary regenerators are also used in chemical plants and in preheating combustion air in electricity generation plants for waste heat utilization. Ceramic regenerators are used for high-temperature incinerators and the vehicular gas turbine power plant. In air-conditioning and industrial process heat recovery applications, heat wheels are made from knitted aluminum or stainless steel wire matrix, wound polyester film, plastic films, and honeycombs. Even paper, wettable nylon, and polypropylene are used in the enthalpy or hygroscopic wheels used in heating and ventilating applications in which moisture is transferred in addition to sensible heat.

1.5.4.2 Fixed-Matrix Regenerator. This type is also referred to as a *periodic-flow, fixed-bed, valved, or stationary regenerator*. For continuous operation, this exchanger has at least two identical matrices operated in parallel, but usually three or four, shown in Figs. 1.45 and 1.46, to reduce the temperature variations in outlet-heated cold gas in high-temperature applications. In contrast, in a rotary or rotating hood regenerator, a single matrix is sufficient for continuous operation.

Fixed-matrix regenerators have two types of heat transfer elements: checkerwork and pebble beds. Checkerwork or thin-plate cellular structure are of two major categories: (1) noncompact regenerators used for high-temperature applications [925 to 1600°C (1700 to 2900°F)] with corrosive gases, such as a Cowper stove (Fig. 1.41) for a blast furnace used in steel industries, and air preheaters for coke manufacture and glass melting tanks made of refractory material; and (2) highly compact regenerators used for low- to high-temperature applications, such as in cryogenic process for air separation, in refrigeration, and in Stirling, Ericsson, Gifford, and Vuileumier cycle engines. The regenerator, a key thermodynamic element in the Stirling engine cycle, has only one matrix, and hence it does not have continuous fluid flows as in other regenerators. For this reason, we do not cover the design theory of a Stirling regenerator.

Cowper stoves are very large with an approximate height of 35 m (115 ft) and diameter of 7.5 m (25 ft). They can handle large flow rates at inlet temperatures of up to 1200°C (2200°F). A typical cycle time is between 1 and 3 h. In a Cowper stove, it is highly desirable to have the temperature of the outlet heated (blast) air approximately constant with time. The difference between the outlet temperatures of the blast air at the beginning and end of a period is referred to as a *temperature swing*. To minimize the temperature swing, three or four stove regenerators, shown in Figs. 1.45 and 1.46, are employed. In the *series parallel arrangement* of Fig. 1.45, part of the cold air (blast) flow is bypassed around the stove and mixed with the heated air (hot blast) leaving the stove. Since the stove cools as the blast is blown through it, it is necessary constantly to decrease the amount of the blast bypassed while increasing the blast through the stove by a corre-

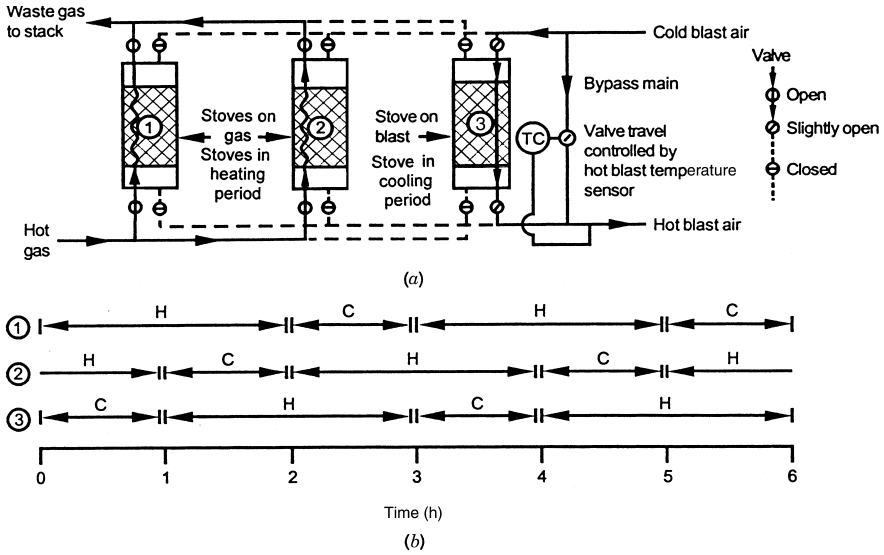

FIGURE 1.45 (a) Three-stove regenerator with series-parallel arrangement; (b) operating schedule. H, hot-gas period; C, blast period (Shah, 1981).

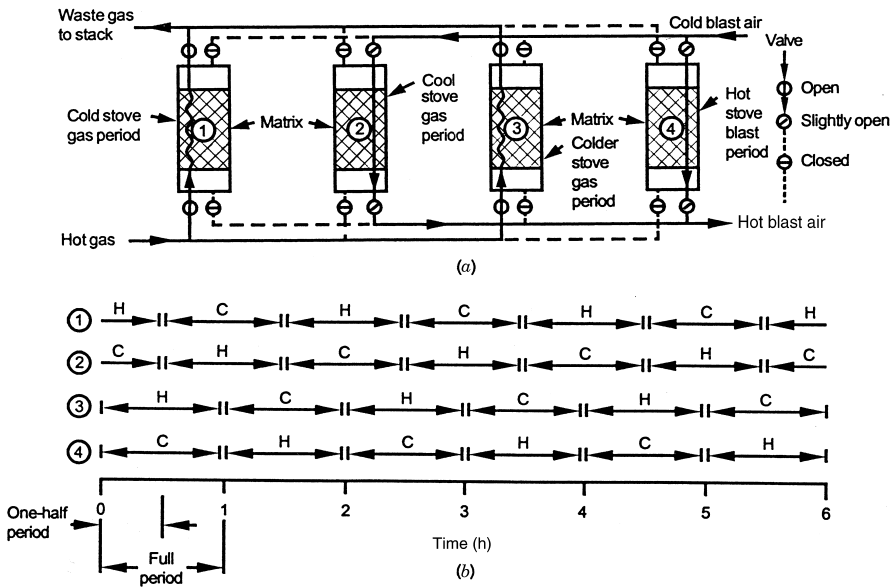

FIGURE 1.46 (a) Four-stove regenerator with staggered parallel arrangement; (b) operating schedule. H, hot-gas period; C, blast period (Shah, 1981).

sponding amount to maintain the hot blast temperature approximately constant. In the *staggered parallel arrangement* of Fig. 1.46, two stoves on air are maintained out of phase by one-half period. In this arrangement, cold blast is routed through a “hot” stove and a “cool” stove (i.e., through which a cold blast has blown for one-half period) rather than being bypassed. The amount of blast through the hot stove is constantly increased while that through the cool stove is decreased by the same amount to maintain the hot blast air temperature approximately constant. At the end of one-half period, the hot stove’s inlet valve is fully open and the cool stove’s inlet valve is fully closed. At this point, the cool stove is put “on gas,” the hot stove becomes the cool stove, and a new hot stove is switched in.

The heat transfer surface used in the aforementioned high-temperature fixed-matrix regenerator is made of refractory bricks, referred to simply as *checkerwork*. The commonly used checker shapes’ surface area density range is 25 to 42 m²/m³ (8 to 13 ft²/ft³), as shown in Fig. 1.47. The checker flow passage (referred to as a *flue*) size is relatively large, primarily to accommodate the fouling problem associated with highly corrosive hot exhaust gases coming to the regenerator. A typical heat transfer coefficient in such a passage is about 5 W/m² · K (1 Btu/hr-ft²-°F).

The surface geometries used for a compact fixed-matrix regenerator are similar to those used for rotary regenerators. The surface geometries used for packed beds are quartz pebbles, steel, copper, or lead shots, copper wool, packed fibers, powders, randomly packed woven screens, and crossed rods. Heat transfer surface area densities of 82,000 m²/m³ (25,000 ft²/ft³) are achievable; the heat transfer coefficient range is 50 to 200 W/m² · K (9 to 35 Btu/hr-ft²-°F).

The design flexibility of selecting different frontal areas is not possible for a fixed-matrix regenerator having multiple matrices, but instead, different hot and cold flow periods are selected. The pressure leakage in a fixed-matrix regenerator is through the “imperfect” valves after wear and tear and through the cracks of matrix walls. Fixed-matrix regenerators can be used for large flow rates and can have very large surface areas and high-heat-capacity material, depending on the design requirements.

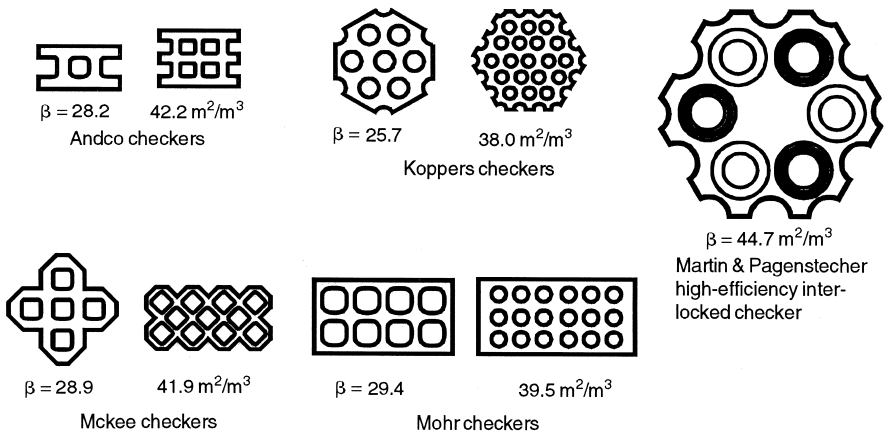

FIGURE 1.47 Checkers used for a blast furnace regenerator (Shah, 1981).

1.6 CLASSIFICATION ACCORDING TO FLOW ARRANGEMENTS

Common flow arrangements of the fluids in a heat exchanger are classified in Fig. 1.1. The choice of a particular flow arrangement is dependent on the required exchanger effectiveness, available pressure drops, minimum and maximum velocities allowed, fluid flow paths, packaging envelope, allowable thermal stresses, temperature levels, piping and plumbing considerations, and other design criteria. Let us first discuss the concept of multipassing, followed by some of the basic ideal flow arrangements for a two-fluid heat exchanger for single- and multipass heat exchangers.

Multipassing. The concept of multipassing applies separately to the fluid and heat exchanger. A *fluid* is considered to have made one pass if it flows through a section of the heat exchanger through its full length. After flowing through one full length, if the flow direction is reversed and fluid flows through an equal- or different-sized section, it is considered to have made a second pass of equal or different size. A *heat*

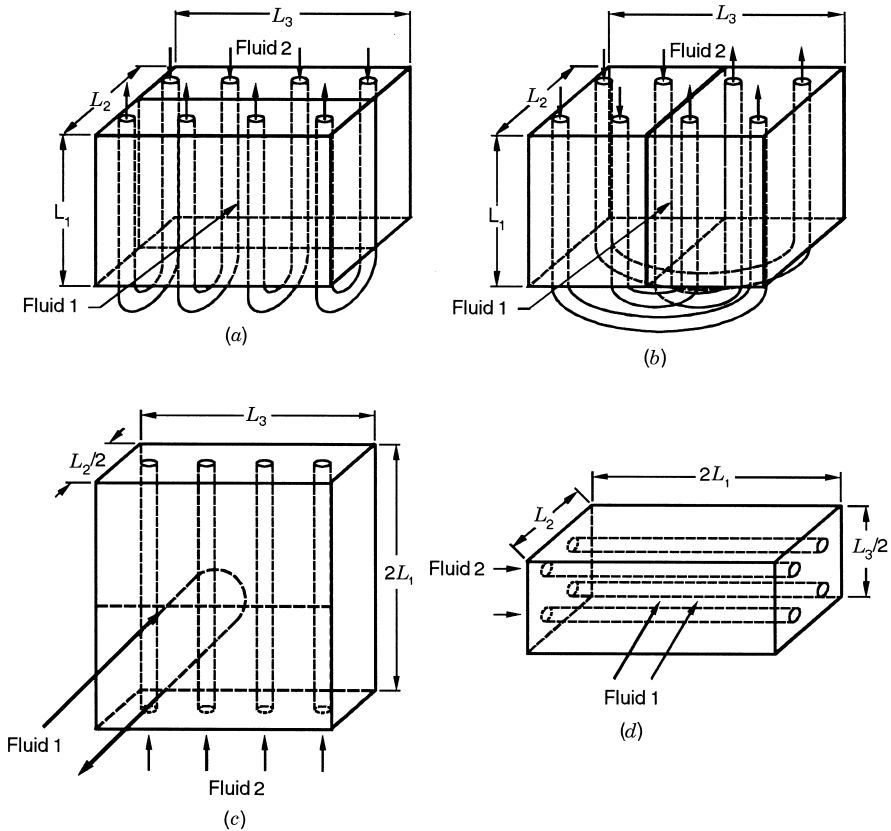

FIGURE 1.48 (a) Two-pass cross-counterflow exchanger; (b) single-pass crossflow exchanger; (c, d) unfolded exchangers of (a) and (b), respectively.

exchanger is considered as a single-pass unit if both fluids make one pass in the exchanger or if it represents any of the single-pass flow arrangements when the multi-pass fluid side is unfolded (note that the folding is used to control the envelope size). To illustrate the concept, consider one exchanger with two different designs of inlet headers for fluid 2 as shown in Fig. 1.48*a* and *b*; fluid 1 makes a single pass, and fluid 2 makes two passes in both exchangers. If the exchanger of Fig. 1.48*b* with fluid 2 unmixed in the headers is unfolded to the horizontal direction (the exchanger length for fluid 2 will be $2L_1$), as in Fig. 1.48*d*,[†] the resulting geometry is a single-pass exchanger having the same inlet temperatures as fluids 1 and 2 of Fig. 1.48*b*. Hence, the exchanger of Fig. 1.48*b* is considered a *single-pass exchanger* from the exchanger analysis point of view. In contrast, the temperature of fluid 1 at the inlet to the first and second pass of fluid 2 is different in Fig. 1.48*a*. Hence, when it is unfolded vertically as in Fig. 1.48*c*, the inlet temperature of fluid 1 to each half of the exchanger will be different, due to the presence of two passes, each with one-half of the original flow length L_2 . This does not correspond to a single-pass exchanger of the unfolded exchanger height. Therefore, the exchanger of Fig. 1.48*a* is considered as a *two-pass exchanger*. An additional degree of freedom is introduced by unfolding. This degree of freedom describes how to lead a fluid between the passes (see, e.g., the case considered in Fig. 1.48*c*, fluid 1). Depending on how the fluid is routed from the exit of one pass to the inlet of the following pass, several distinct flow arrangements can be identified (see Section 1.6.2.1 for further details).

1.6.1 Single-Pass Exchangers

1.6.1.1 Counterflow Exchanger. In a counterflow or countercurrent exchanger, as shown in Fig. 1.49*a*, the two fluids flow parallel to each other but in opposite directions within the core.[‡] The temperature variation of the two fluids in such an exchanger may be idealized as one-dimensional, as shown in Fig. 1.50. As shown later, the counterflow arrangement is thermodynamically superior to any other flow arrangement. It is the most efficient flow arrangement, producing the highest temperature change in each fluid compared to any other two-fluid flow arrangements for a given overall thermal conductance (UA), fluid flow rates (actually, fluid heat capacity rates), and fluid inlet temperatures. Moreover, the maximum temperature difference across the exchanger wall thickness (between the wall surfaces exposed on the hot and cold fluid sides) either at the hot- or cold-fluid end is the lowest, and produce minimum thermal stresses in the wall for an equivalent performance compared to any other flow arrangements. However, with plate-fin heat exchanger surfaces, there are manufacturing difficulties associated with the true counterflow arrangement. This is because it is necessary to separate the fluids at each end, and the problem of inlet and outlet header design is complex. Some header arrangements are shown in Fig. 1.49*b–f*. Also, the overriding importance of other design factors causes most commercial heat exchangers to be designed for flow arrangements different from single-pass counterflow if extremely high exchanger effectiveness is not required.

[†] In unfolded exchangers of Fig. 1.48*c* and *d*, the U-bend lengths of the tubes are neglected for the present discussion since they do not take an active part in heat transfer between two fluids.

[‡] This flow arrangement can be rigorously identified as a *countercurrent parallel stream*. However, based on Kays and London's (1998) terminology, used widely in the literature, we use the term *counterflow* for this flow arrangement throughout the book.

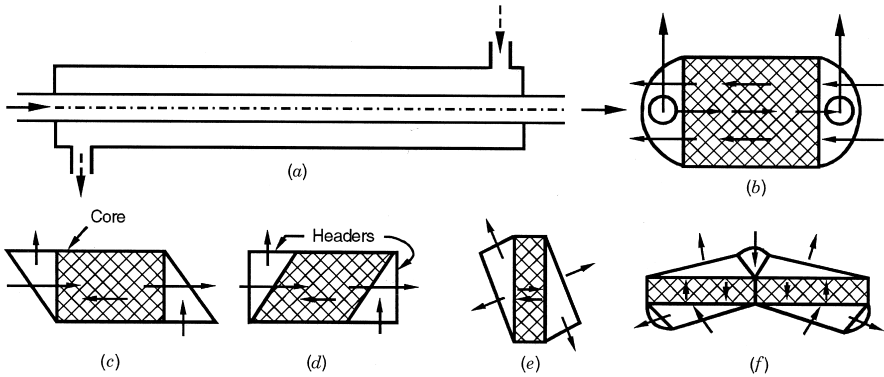

FIGURE 1.49 (a) Double-pipe heat exchanger with pure counterflow; (b-f) plate-fin exchangers with counterflow core and crossflow headers (Shah, 1981).

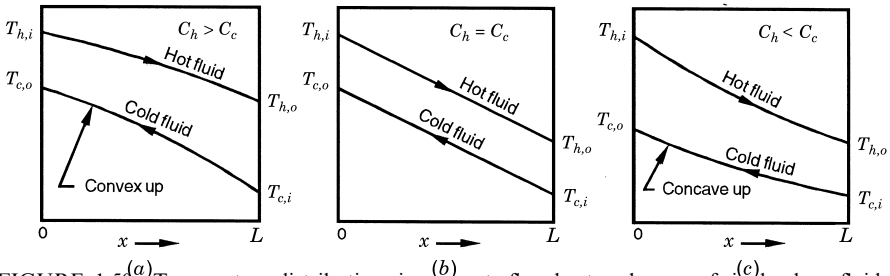

FIGURE 1.50 (a) Temperature distributions in a counterflow heat exchanger of single-phase fluids (no boiling or condensation). Here $C_h = (\dot{m}c_p)_h$ is the heat capacity rate of the hot fluid, C_c is the heat capacity rate of the cold fluid, and specific heats c_p are treated as constant. The symbol T is used for temperature; the subscripts h and c denote hot and cold fluids, and subscripts i and o represent the inlet and outlet of the exchanger (Shah, 1981).

Typical temperature distributions for a counterflow regenerator are shown in Fig. 1.51. Note that the wall temperature fluctuates periodically between the solid line limits shown. Also compare the similarity between the fluid temperature distributions of Fig. 1.50 for $C_h = C_c$ and those of Fig. 1.51b.

1.6.1.2 Parallelflow Exchanger. In a parallelflow (also referred to as *cocurrent* or *cocurrent parallel stream*) exchanger, the fluid streams enter together at one end, flow parallel to each other in the same direction, and leave together at the other end. Figure 1.49a with the dashed arrows reversed would then depict parallelflow. Fluid temperature variations, idealized as one-dimensional, are shown in Fig. 1.52. This arrangement has the lowest exchanger effectiveness among single-pass exchangers for given overall thermal conductance (UA) and fluid flow rates (actually, fluid heat capacity rates) and fluid inlet temperatures; however, some multipass exchangers may have an even lower effectiveness, as discussed later. However, for low-effectiveness exchangers, the difference in parallelflow and counterflow exchanger effectiveness is small. In a parallelflow exchanger, a large temperature difference between inlet temperatures of hot and cold fluids

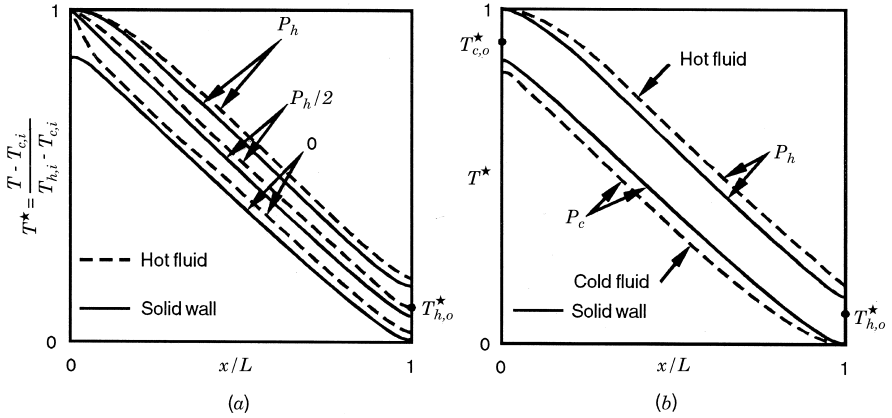

FIGURE 1.51 (a) Hot-side solid and fluid temperature excursion; (b) balanced ($C_h = C_c$) regenerator temperature distributions at the switching instant (Shah, 1991b).

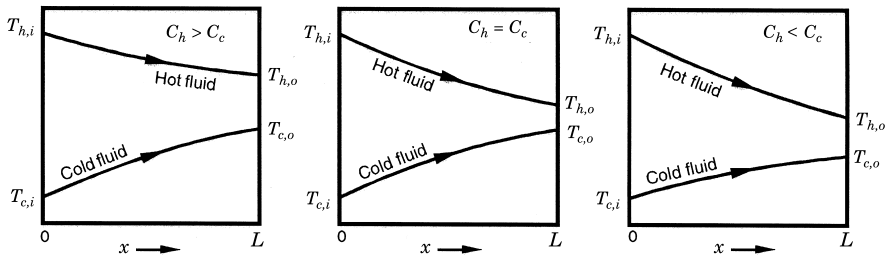

FIGURE 1.52 Temperature distributions in a parallelflow heat exchanger (Shah, 1981).

exists at the inlet side, which may induce high thermal stresses in the exchanger wall at the inlet. Although this flow arrangement is not used for applications requiring high-temperature effectiveness, it may be used in the following applications:

1. It often produces a more uniform longitudinal tube wall temperature distribution and not as high or low tube wall temperature as in a counterflow arrangement at the same surface area (NTU),[†] fluid flow rates (fluid heat capacity rates or C^*), and fluid inlet temperatures (see Example 3.2). For this reason, a parallelflow exchanger is sometimes used with temperature-sensitive materials, highly viscous liquids, and metal recuperators having inlet temperatures in excess of 1100°C (2000°F).
2. The lowest wall temperature for the parallelflow exchanger is *higher* than that for the counterflow or other flow arrangements for the same NTU, C^* , and fluid inlet temperatures, although the exchanger effectiveness will also be lower. Thus, if acid vapors are present in the exhaust gas, the parallelflow arrangement minimizes or

[†] See Sections 3.3.2 and 3.3.3 for definitions of C^* and NTU.

avoids condensation of acid vapors and hence corrosion of the metal surface. The parallelflow exchanger may be preferred when there is a possibility that the temperature of the warmer fluid may reach its freezing point.

3. The highest wall temperature for the parallelflow exchanger is *lower* than that for the counterflow or other flow arrangements for the same NTU, C^* , and inlet temperatures. This may eliminate or minimize the problems of fouling, wall material selections, and fluid decomposition.
4. It provides early initiation of nucleate boiling for boiling applications.
5. A large change in NTU causes a relatively small change in ϵ for $NTU > 2$, as shown in Fig. 3.8. Thus a parallelflow exchanger is preferred if the desired exchanger effectiveness is low and is to be maintained approximately constant over a large flow rate range (e.g., for $NTU \sim 1$ to 5 or higher at $C^* = 1$, see Fig. 3.8).
6. The application allows piping suited only to parallelflow.

1.6.1.3 Crossflow Exchanger. In this type of exchanger, as shown in Fig. 1.53, the two fluids flow in directions normal to each other. Typical fluid temperature variations are idealized as two-dimensional and are shown in Fig. 1.54 for the inlet and outlet sections only. Thermodynamically, the effectiveness for the crossflow exchanger falls in between that for the counterflow and parallelflow arrangements. The largest structural temperature difference exists at the “corner” of the entering hot and cold fluids, such as point *a* in Fig. 1.54. This is one of the most common flow arrangements used for extended-surface heat exchangers, because it greatly simplifies the header design at the entrance and exit of each fluid. If the desired heat exchanger effectiveness is high (such as greater than 80%), the size penalty for the crossflow exchanger may become excessive. In such a case, a counterflow unit is preferred. This flow arrangement is used in a TEMA X shell (see Fig. 1.6) having a single tube pass. The length L_3 (or the “height” in the *x* direction)

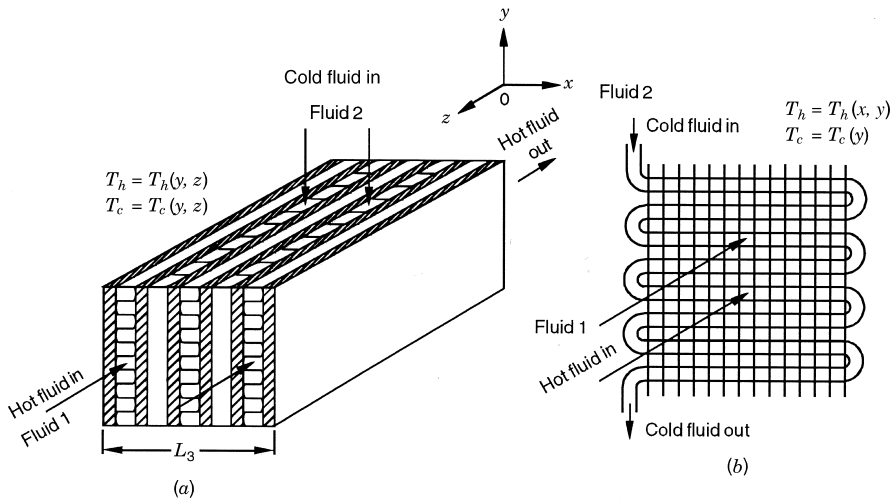

FIGURE 1.53 (a) Plate-fin unmixed–unmixed crossflow heat exchanger; (b) serpentine (one tube row) tube-fin unmixed–mixed crossflow heat exchanger (Shah, 1981).

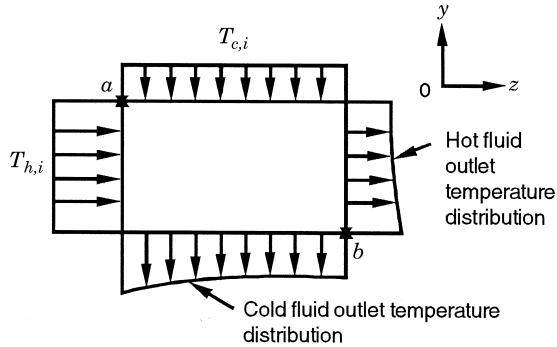

FIGURE 1.54 Temperature distributions at inlets and outlets of an unmixed–unmixed crossflow heat exchanger (Shah, 1981).

in Fig. 1.53a does not represent the flow length for either fluid 1 or fluid 2. Hence, it is referred to as *no-flow height* or *stack height* since the fins are stacked in the L_3 direction.

In a crossflow arrangement, *mixing* of either fluid stream may or may not occur, depending on the design. A fluid stream is considered *unmixed* when it passes through individual flow channels or tubes with no fluid mixing between adjacent flow channels. In this case within the exchanger, temperature gradients in the fluid exist in at least one direction (in the transverse plane) normal to the main fluid flow direction. A fluid stream is considered completely *mixed* when no temperature gradient exists in the transverse plane, either within one tube or within the transverse tube row within the exchanger. Ideally, the fluid thermal conductivity transverse to the flow is treated as zero for the unmixed-fluid case and infinity for the mixed-fluid case. Fluids 1 and 2 in Fig. 1.53a are unmixed. Fluid 1 in Fig. 1.53b is unmixed, while fluid 2 is considered mixed because there is only one flow channel. The temperature of an unmixed fluid, such as fluid 1 in Fig. 1.53, is a function of two coordinates z and y within the exchanger, and it cannot be treated as constant across a cross section (in the y direction) perpendicular to the main flow direction x . Typical temperature distributions of the unmixed fluids at exchanger outlet sections are shown in Fig. 1.54. The outlet temperature from the exchanger on the unmixed side is defined as a mixed mean temperature that would be obtained after complete mixing of the fluid stream at the exit. For the cases of Fig. 1.53, it is idealized that there is no variation of the temperature of either fluid in the x direction. The temperature of a mixed fluid (fluid 2 in Fig. 1.53b) is mainly dependent on the coordinate y . The temperature change per pass (in the x direction) of fluid 2 in Fig. 1.53b is small compared to the total.

In a multiple-tube-row tubular crossflow exchanger, the tube fluid in any one tube is considered mixed at any cross section. However, when split and distributed in different tube rows, the incoming tube fluid is considered unmixed between the tube rows. Theoretically, it would require an infinite number of tube rows to have a truly unmixed fluid on the tube side. In reality, if the number of tube rows is greater than about four, it will practically be an unmixed side. For an exchanger with fewer than about four or five tube rows, the tube side is considered partially unmixed or partially mixed. Note that when the number of tube rows is reduced to one, the tube fluid is considered mixed.

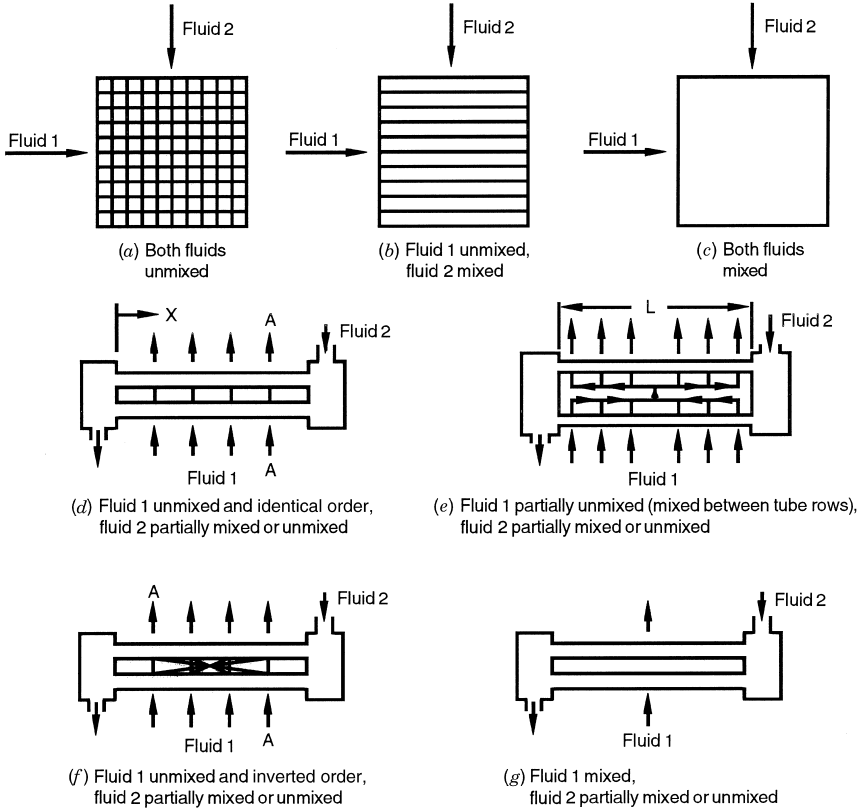

FIGURE 1.55 Symbolic presentation of various degrees of mixing in a single-phase crossflow exchanger.

Mixing thus implies that a thermal averaging process takes place at each cross section across the full width of the flow passage. Even though the truly unmixed and truly mixed cases are the extreme idealized conditions of a real situation in which some mixing exists, the unmixed condition is nearly satisfied in many plate-fin and tube-fin (with flat fins) exchanger applications. As will be shown in Section 11.3 and in the discussion of Example 3.5, for the same surface area and fluid flow rates, (1) the exchanger effectiveness generally decreases with increasing mixing on any fluid side, although counter examples can be found in the multipass case; and (2) if the C_{\max} fluid is placed on the unmixed fluid side, the exchanger effectiveness and performance will be higher than that for placing C_{\max} on the mixed fluid side.

Seven idealized combinations of flow arrangements for a single-pass crossflow exchanger are shown symbolically in Fig. 1.55. The flow arrangements are:

- (a) *Both fluids unmixed.* A crossflow plate-fin exchanger with plain fins on both sides represents the “both fluids unmixed” case.
- (b) *One fluid unmixed, the other mixed.* A crossflow plate-fin exchanger with fins on one side and a plain gap on the other side would be treated as the unmixed–mixed case.

- (c) *Both fluids mixed.* This case is practically less important, and represents a limiting case of some multipass shell-and-tube exchangers (e.g., $1-\infty$ TEMA E and J), as presented later.
- (d) *One fluid unmixed and coupled in identical order, the other partially mixed.* Here *identical order* refers to the fact that a fluid coupled in such order leaves the first row at the point where the other fluid enters (leaves) the first row, and enters the other row where the second fluid enters (leaves) that row (see the stream AA in Fig. 1.55d). A tube-fin exchanger with flat fins represents the case of tube fluid partially mixed, the fin fluid unmixed. When the number of tube rows is reduced to one, this exchanger reduces to the case of out-of-tube (fin) fluid unmixed the tube fluid mixed (case b). When the number of tube rows approaches infinity (in reality greater than four), the exchanger reduces to the case of both fluids unmixed (case a).
- (e) *One fluid partially unmixed, the other partially mixed.* The case of one fluid (fluid 1) partially unmixed (i.e., mixed only between tube rows) and the other (fluid 2) partially mixed (see Fig. 1.55e) is of less practical importance for single-pass crossflow exchangers. However, as mentioned later (see the middle sketch of Fig. 1.58b with the notation of fluids 1 and 2 interchanged),[†] it represents the side-by-side multipass crossflow arrangement. When the number of tube rows is reduced to one, this exchanger is reduced to the case of out-of-tube fluid unmixed, the tube fluid mixed. When the number of tube rows approaches infinity, the exchanger reduces to the case of out-of-tube fluid mixed, the tube fluid unmixed.
- (f) *One fluid unmixed and coupled in inverted order, the other partially mixed.* Here, the term *inverted order* refers to the fact that a fluid coupled in such order leaves the first row at the point where the other fluid enters (leaves) the first row and enters the other row where the second fluid leaves (enters) that row (see the stream AA in Fig. 1.55f). This case is also of academic interest for single-pass crossflow exchangers.
- (g) *One fluid mixed, the other partially mixed.* This is the case realized in plain tubular crossflow exchangers with a few tube rows.

1.6.1.4 Split-Flow Exchanger, TEMA G Shell. In this exchanger, shown in Fig. 1.56a, the shell fluid stream enters at the center of the exchanger and divides into two streams. These streams flow in longitudinal directions along the exchanger length over a longitudinal baffle, make a 180° turn at each end, flow longitudinally to the center of the exchanger under the longitudinal baffle, unite at the center, and leave from the central nozzle. The other fluid stream flows straight in the tubes. Typical temperature distributions for the two fluids in this exchanger are shown in Fig. 1.56. This single-pass flow arrangement is found in the TEMA G shell (see Fig. 1.6). Another variant is a double-split flow arrangement, as found in the TEMA H shell (see Fig. 1.6), again having a single tube pass.

[†] In Fig. 1.58b, this means fluid 1 partially mixed (considering mixed in each individual passes) and fluid 2 partially unmixed (i.e., unmixed within a pass and mixed between passes).

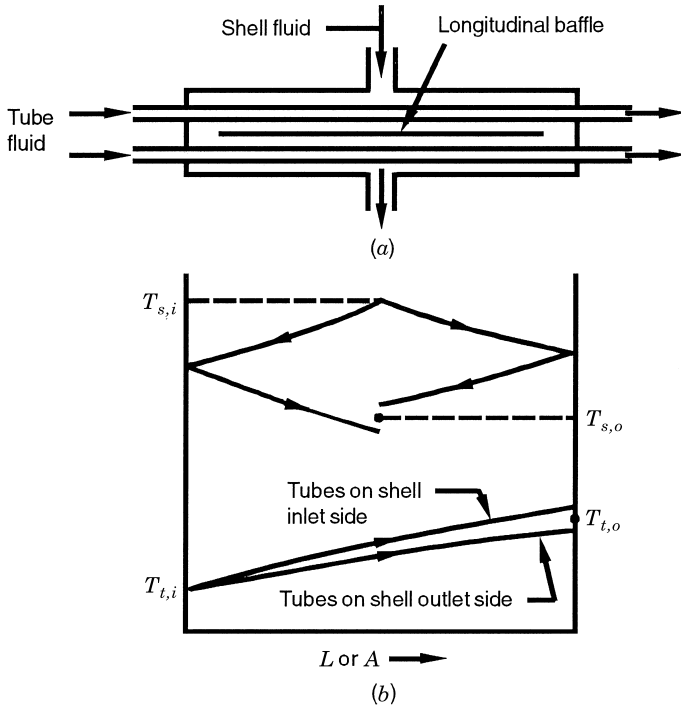

FIGURE 1.56 (a) Single-pass split-flow (TEMA G) exchanger; (b) idealized shell fluid and tube fluid temperature distributions.

1.6.1.5 Divided-Flow Exchanger, TEMA J Shell. In this exchanger as shown in Fig. 1.57a, the shell fluid stream enters at the center of the exchanger and divides into two streams. These streams flow ideally in longitudinal directions along the exchanger length and exit from two nozzles, one at each end of the exchanger. The other fluid stream flows straight in the tubes. Typical temperature distributions for the two fluids are shown in Fig. 1.57b. This flow arrangement is found in the TEMA J shell having a single tube pass.

1.6.2 Multipass Exchangers

When the design of a heat exchanger results in either an extreme length, significantly low fluid velocities, or a low effectiveness (sometimes maybe other design criteria), a multipass heat exchanger or several single-pass exchangers in series, or a combination of both, is employed. Heat exchangers in any of the five basic flow arrangements of Section 1.6.1 can be put into series to make a multipass unit. In addition, there exist other multipass flow arrangements that have no single-pass counterpart. One of the major advantages of proper multipassing is to increase the exchanger overall effectiveness over the individual pass effectivenesses, but with increased pressure drop on the multipass side. If the overall direction of the two fluids is chosen as counterflow (see Figs. 1.58a left and 1.62), the exchanger overall effectiveness approaches that of a pure counterflow exchanger as

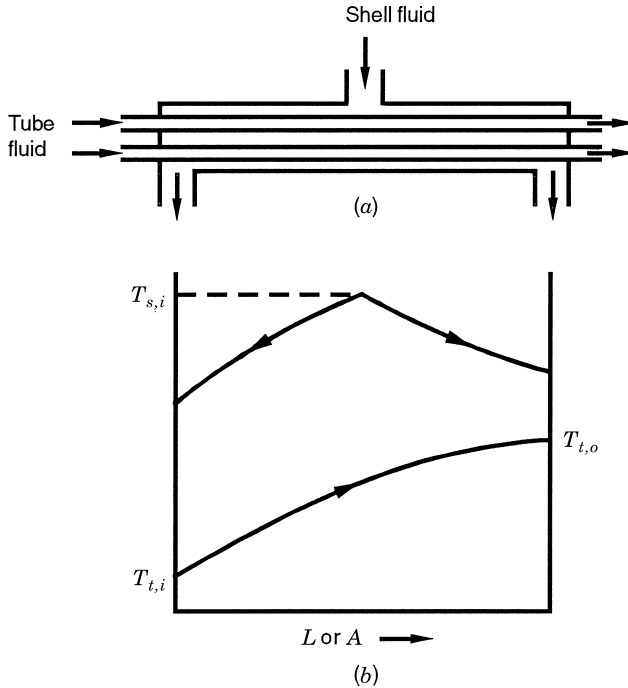

FIGURE 1.57 (a) Single-pass divided-flow (TEMA J) exchanger with shell fluid mixed; (b) idealized shell and tube fluid temperature distributions.

the number of passes increases. The multipass arrangements are classified according to the type of construction: for example, extended surface, shell-and-tube, or plate exchangers (see Fig. 1.1).

1.6.2.1 Multipass Crossflow Exchangers. This arrangement is the most common for extended surface exchangers; two or more passes are put in series, with each pass usually having crossflow, although any one of the single-pass basic flow arrangements could be employed. The flow arrangements could be categorized as (a) a *series coupling* of n passes or *over-and-under passes*, (b) a *parallel coupling* of n passes or *side-by-side passes*, and (c) a combination of both or a compound arrangement. These are shown in Fig. 1.58. Each module in Fig. 1.58 can be either an individual pass or an individual heat exchanger. In the series coupling of n passes, each of the fluid streams is in series; whereas in the parallel coupling of n passes, one fluid stream is in series, the other in parallel. The parallel coupling (side-by-side) two-pass arrangement is also referred to as the *face-U flow arrangement*. For the same surface area, fluid flow rates and inlet temperatures, a series-coupled *overall counterflow* multipass exchanger yields higher effectiveness and heat transfer rate than that for a parallel-coupled multipass exchanger, as will be shown in Example 3.5. In a series-coupled multipass exchanger, usually the flow direction is chosen such that an overall counterflow is obtained, as shown in Fig. 1.58a, to obtain higher exchanger effectiveness. This arrangement is then referred to as n -pass *cross-counterflow*. If the direction of fluid 2 in Fig. 1.58a is reversed, overall

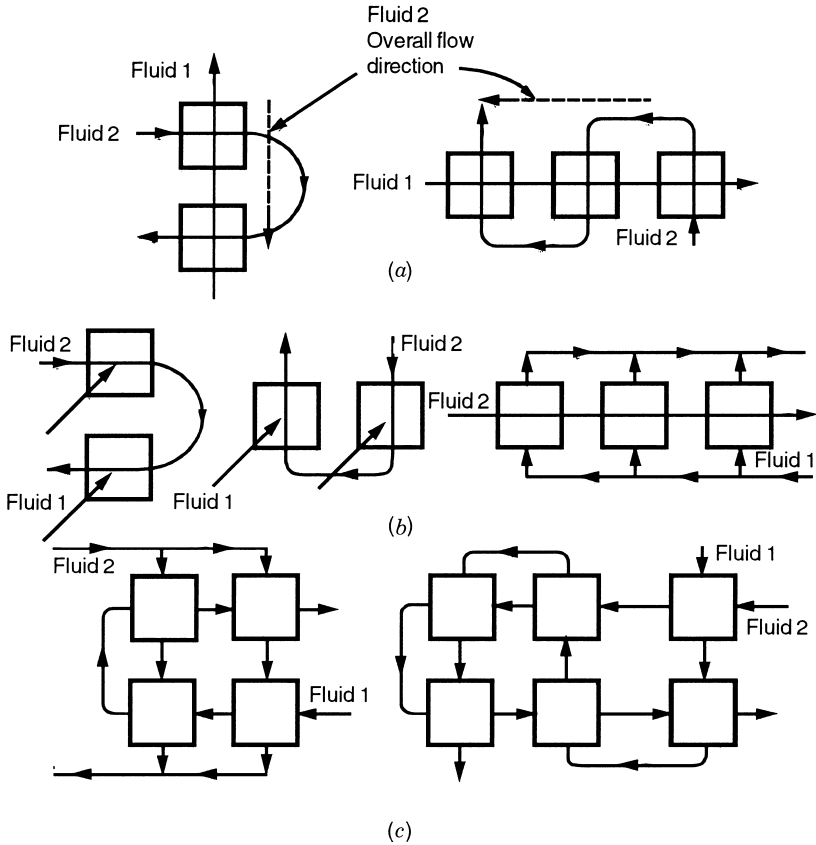

FIGURE 1.58 Examples of multipass exchangers: (a) series coupling or over-and-under pass arrangement; (b) parallel coupling or side-by-side pass arrangement; (c) compound coupling.

parallelflow would be achieved, and it is referred to as an *n-pass cross-parallelflow* arrangement. The latter arrangement is used to prevent freezing of the hot fluid (such as water) in the core near the inlet of the cold fluid (such as air). There are a large number of combinations of the foregoing basic multipass arrangements yielding compound multipass arrangements. No specific broadly accepted classification scheme has emerged for compound multipass arrangements.

Now let us introduce additional basic terminology for series-coupled multipass exchangers. The exchanger effectiveness of any of the foregoing multipass crossflow exchangers depends on whether the fluids are mixed, partially unmixed, or fully unmixed within each pass and mixed or unmixed between passes on each fluid side, in addition to independent variables for single-pass exchangers. When the fluids are unmixed between passes (in the pass return or header), the exchanger effectiveness is dependent on how the fluid is distributed in the header, whether in identical or inverted order, and which fluid has larger heat capacity rate. As shown in Fig. 1.59a, consider two rows per pass for the tube fluid and the air flows across the tubes in sequence of rows 1 through 4 in the direction of arrows. The tube fluid in row 1 (the first tube in pass 1) is first in contact

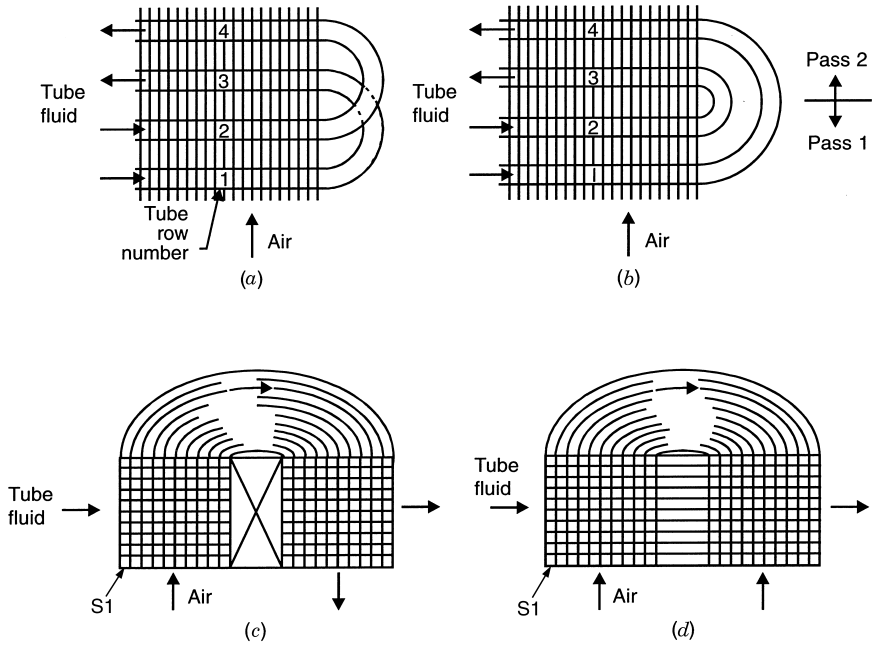

FIGURE 1.59 Two-pass cross-parallelflow exchangers with both fluids unmixed throughout. For the *tube fluid* in the pass return: (a) identical order; (b) inverted order. Cases (c) and (d) are symbolic representations of cases (a) and (b), respectively. In both cases (a) and (b), air (out-of-tube fluid) is in inverted order.

with the air in pass 1, and the *same* fluid in row 3 (the first tube in pass 2) is first in contact with air in pass 2. The tube fluid between passes for this arrangement is then defined to be in identical order. In Fig. 1.59b, the tube fluid stream in row 1 (the first tube in pass 1) is again first in contact with air in pass 1. However, the *different* fluid stream (or row connected to the second tube in pass 1) makes the first contact with air in pass 2. In this arrangement, the tube fluid between passes is said to be in inverted order. In either Fig. 1.59a or b, the air-side fluid is in inverted order between passes. This is because the airstream that crossed the tube inlet end in the first pass then crosses the tube exit end in the second pass (see the first vertical airstream, S1 in Fig. 1.59c and d). Figures 1.59a and b are represented symbolically as Fig. 1.59c and d, respectively, since one does not have always tubes in the exchanger, for example, in a plate-fin multipass exchanger.

Multipassing of crossflow exchangers retains the header and ducting advantages of a simple crossflow exchanger, while it is possible to approach the thermal performance of a true counterflow heat exchanger using an overall cross-counterflow arrangement. The maximum temperature differences in the wall across the wall thickness direction (sometimes referred to as *structural temperature differences*) are considerably reduced in a multipass cross-counterflow exchanger relative to a single-pass crossflow design for the same terminal temperatures. For high-temperature applications (approximately above 450°C or 850°F), the heat exchanger can be divided into two or more passes having distinct operating temperature ranges. Special metals (such as stainless steel and superalloys) may be used in passes having high operating temperatures, and ordinary metals

(such as aluminum or copper) could be used in moderate to low operating temperatures, thus achieving substantial cost savings and improved durability of the exchanger.

1.6.2.2 Multipass Shell-and-Tube Exchangers. When the number of tube passes is greater than one, the shell-and-tube exchangers with any of the TEMA shell types (except for the F shell) represent a multipass exchanger. Since the shell-side fluid flow arrangement is unique with each shell type, the exchanger effectiveness is different for each shell even though the number of tube passes may be the same. For illustrative purposes, in the following subsections, two tube passes (as in a U-tube bundle) are considered for the multipass shell-and-tube exchangers having E, G, H, and J shells. However, more than two tube passes are also common, as will be mentioned later. The ideal flow arrangement in the F shell with two tube passes is a pure counterflow arrangement as considered with single-pass exchangers and as can be found by unfolding the tubes. Since the liquid is evaporating on the shell side in the K shell (as a kettle reboiler application), it represents the $C^* = 0$ case and can be analyzed using the single-pass exchanger results, as will be explained with Eq. (3.84) and in item 4 after Eq. (3.88). The flow arrangement with the X shell having two or more tube passes represents an overall cross-counterflow or cross-parallelflow arrangement, as described for extended surface exchangers, depending on the overall directions of the two fluids. Hence, only the unique multipass arrangements used in shell-and-tube exchangers are summarized next.

Parallel Counterflow Exchanger, TEMA E Shell. This is one of the most common flow arrangements used in single-phase shell-and-tube heat exchangers, and is associated with the TEMA E shell. One of the simplest flow arrangements is one shell pass and two tube passes, as shown in Fig. 1.60 using a U-tube bundle. A heat exchanger with this arrangement is also simply referred to as a conventional 1–2 *heat exchanger* by industry and in this book, although the more precise terminology would be 1–2 TEMA

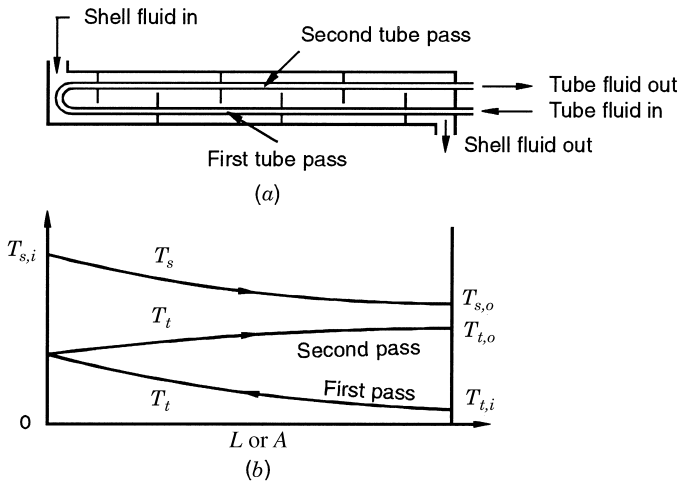

FIGURE 1.60 (a) A 1–2 TEMA E heat exchanger (one shell pass and two tube passes); (b) corresponding temperature distributions.

E exchanger. Similarly, we simply designate the 1–2*n* TEMA E exchanger as the 1–2*n* exchanger.

As the tubes are rigidly mounted only at one end, thermal expansion is readily accommodated. If the shell fluid is idealized as *well mixed*, its temperature is constant at any cross section but changes from a cross section to another cross section along the shell length direction. In this case, reversing the tube fluid flow direction will not change the idealized temperature distribution of Fig. 1.60*b* and the exchanger effectiveness.

Increasing the even number of tube passes of a 1–2*n* exchanger from two to four, six, and so on, decreases the exchanger effectiveness slightly, and in the limit when the number of tube passes approaches infinity with one shell pass, the exchanger effectiveness approaches that for a single-pass crossflow exchanger with both fluids mixed. Common tube-side multipass arrangements are shown in Fig. 1.61.[†]

The odd number of tube passes per shell has slightly better effectiveness when the shell fluid flows countercurrent to the tube fluid for more than one half the tube passes. However, this is an uncommon design and may result in structural and thermal problems in manufacturing and design.

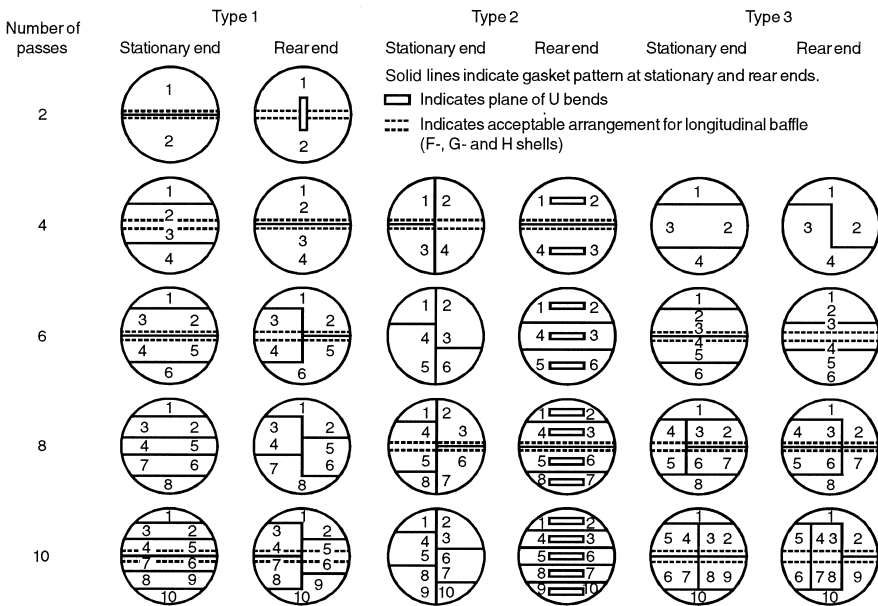

FIGURE 1.61 Common tube-side multipass arrangements in shell-and-tube exchangers (to simplify the sketches, tubes are not shown in the cross section of the exchanger). The solid lines indicate pass ribs in the front header; the dashed lines represent pass ribs in the rear header (From Saunders, 1988).

[†] Each sketch in Fig. 1.61 represents a cross section of the shell and tube fluid nozzles at the inlet and pass partitions. The dashed lines are the pass partitions on the other end of the tube bundle. No tubes or baffles are shown for clarity. Also, no horizontal orientation of the nozzles is shown, although horizontal nozzles are common for some applications.

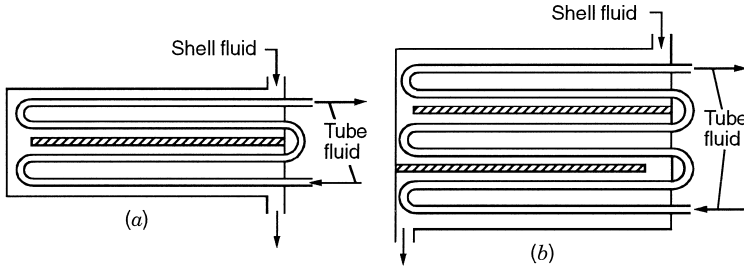

FIGURE 1.62 (a) Two shell pass-four tube pass exchanger; (b) three shell pass-six tube pass exchanger.

Since the $1-2n$ exchanger has a lower effectiveness than that of a counterflow exchanger, multipassing of the basic $1-2$ arrangement may be employed with multiple shells (each shell as a $1-2$ exchanger) to approach the counterflow effectiveness. The heat exchanger with the most general flow arrangement would have m shell passes and n tube passes. Figure 1.62 represents two such exchangers.

Split-Flow Exchanger, TEMA G Shell. In this exchanger, there is one central inlet and one central outlet nozzle with a longitudinal baffle, as shown in Fig. 1.63a. Typical temperature distribution is shown in Fig. 1.63b. This arrangement is used in the TEMA

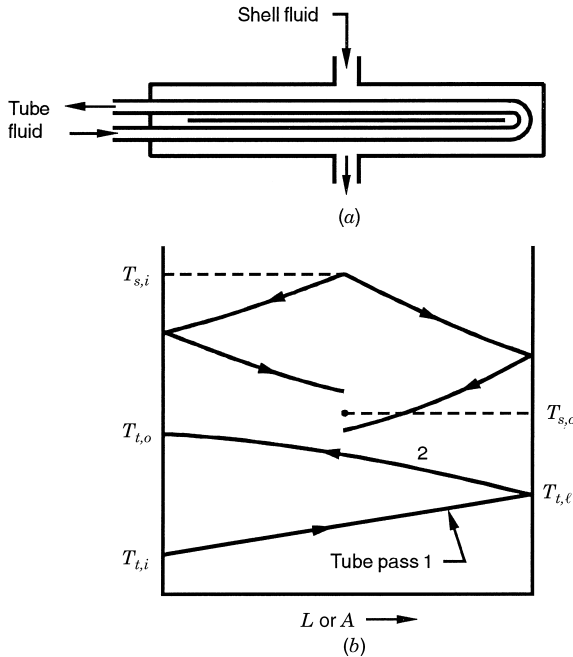

FIGURE 1.63 (a) A 1-2 split flow (TEMA G) exchanger; (b) idealized shell fluid and tube fluid temperature distributions.

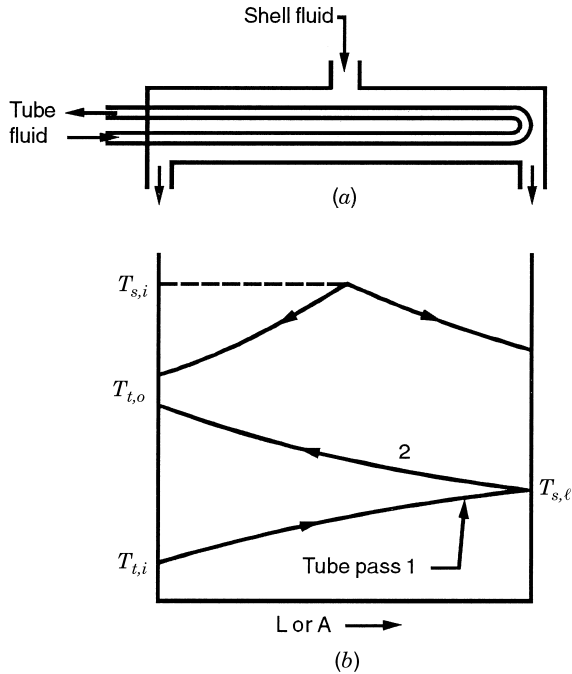

FIGURE 1.64 (a) A 1–2 divided flow (TEMA J) exchanger with shell fluid mixed; (b) idealized shell fluid and tube fluid temperature distributions.

G shell. It is a variant of the conventional 1–2 exchanger. As the “mixing” is less severe than that for the 1–2 exchanger of Fig. 1.60, the exchanger effectiveness is slightly higher, particularly at high NTU values. A double split-flow arrangement is used in the TEMA H shell.

Divided-Flow Exchanger, TEMA J Shell. In this exchanger, the shell fluid enters at the center, divides into two equal streams, and leaves at both ends, as shown in Fig. 1.64 with typical temperature distributions. The TEMA J shell has this flow arrangement.

1.6.2.3 Multipass Plate Exchanger. In a plate exchanger, although a single-pass counterflow arrangement is common, there exist a large number of feasible multipass flow arrangements, depending on the gasketing around the ports in the plates. Some of them are shown in Fig. 1.65. Essentially, these are combinations of parallelflow and counterflow arrangements with heat transfer taking place in adjacent channels.

One of the common ways of classifying two-fluid plate exchangers is on the basis of the number of passes on each fluid side. Possible arrangements are 1 pass – 1 pass, 2 pass – 1 pass, and so on, multipass arrangements. Usually, the 1 pass – 1 pass plate exchanger has *looped patterns*, the m pass – n pass plate exchanger has the *complex flow* arrangement, and the n pass – n pass plate exchanger has the *series flow* arrangement.

Looped patterns are most commonly used. The flow arrangement represents pure counterflow (although pure parallelflow is also possible) in a single pass. It is used for large flow rates but relatively small temperature drops or rises (ΔT) on each fluid side. Of

the two looped patterns, the U-arrangement (Fig. 1.65*a*) is usually preferred over the Z-arrangement (Fig. 1.65*b*) since it allows all connections to be made on the same side of the frame. This eliminates the need for disconnecting pipework for maintenance and cleaning purposes.

A complex flow arrangement results by combining Z-arrangements in series with a generally identical number of thermal plates in each pass. Although only three such flow arrangements are shown in Fig. 1.65*c-e*, many other combinations are possible (see, e.g., Table 3.6). Primarily, these arrangements are used when there is a significant difference in the flow rates of the two fluid streams and the corresponding available pressure drops. Generally, the fluid, having very low permissible pressure drop, goes through the single pass; the other fluid goes through multiple passes in order to utilize the available pressure drop and pumping power. Also, if the flow rates are significantly different, the fluid having the lower flow rate goes through $n (> 1)$ passes such that in each pass the heat capacity rates of both fluid streams are about equal. This would produce approximately equal heat transfer coefficients on each fluid side, resulting in a balanced exchanger (hA values approximately the same). Multipass arrangements always have ports located on fixed and movable end plates.

In the series flow arrangement (Fig. 1.65*f*), each flow passage represents a pass. The series arrangement is used for small fluid flow rates that must undergo a large temperature difference. It is used for very close temperature approaches. Because of many flow reversals, a significant portion of the available pressure drop is wasted in reversals (i.e., the pressure drop in the series flow arrangement is extremely high). The manifold-

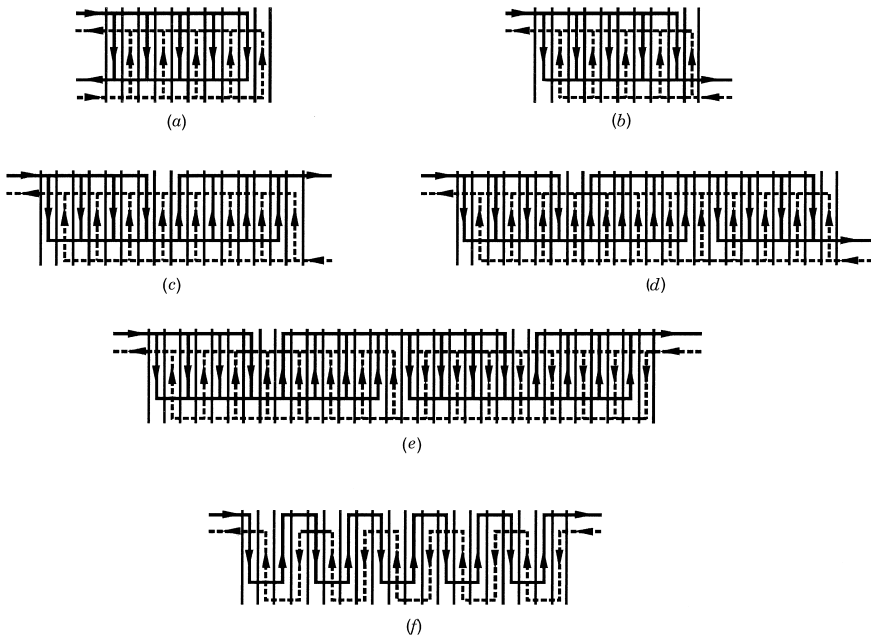

FIGURE 1.65 Single- and multipass plate heat exchanger arrangements. Looped or single-pass arrangements: (a) U arrangement; (b) Z arrangement. Multipass arrangements: (c) 2 pass - 1 pass, (d) 3 pass - 1 pass, (e) 4 pass - 2 pass, and (f) series flow.

induced flow maldistribution (see Section 12.1.3) found in the looped pattern is nonexistent in the series flow arrangement. The series flow is not as effective as pure counterflow because each stream flows parallel to the other fluid stream on one side and counter on the other side. In most pasteurizers, a large section is in series flow.

1.7 CLASSIFICATION ACCORDING TO HEAT TRANSFER MECHANISMS

The basic heat transfer mechanisms employed for transfer of thermal energy from the fluid on one side of the exchanger to the wall (separating the fluid on the other side) are single-phase convection (forced or free), two-phase convection (condensation or evaporation, by forced or free convection), and combined convection and radiation heat transfer. Any of these mechanisms individually or in combination could be active on each fluid side of the exchanger. Such a classification is provided in Fig. 1.1.

Some examples of each classification type are as follows. Single-phase convection occurs on both sides of the following two-fluid exchangers: automotive radiators and passenger space heaters, regenerators, intercoolers, economizers, and so on. Single-phase convection on one side and two-phase convection on the other side (with or without desuperheating or superheating, and subcooling, and with or without noncondensables) occur in the following two-fluid exchangers: steam power plant condensers, automotive and process/power plant air-cooled condensers, gas or liquid heated evaporators, steam generators, humidifiers, dehumidifiers, and so on. Two-phase convection could occur on each side of a two-fluid heat exchanger, such as condensation on one side and evaporation on the other side, as in an air-conditioning evaporator. Multicomponent two-phase convection occurs in condensation of mixed vapors in distillation of hydrocarbons. Radiant heat transfer combined with convective heat transfer plays a role in liquid metal heat exchangers and high-temperature waste heat recovery exchangers. Radiation heat transfer is a primary mode in fossil-fuel power plant boilers, steam generators, coal gasification plant exchangers, incinerators, and other fired heat exchangers.

SUMMARY

Heat exchangers have been classified according to transfer processes, number of fluids, degrees of surface compactness, construction features, flow arrangements, and heat transfer mechanisms. A summary is provided in Fig. 1.1. The major emphasis in this chapter is placed on introducing the terminology and concepts associated with a broad spectrum of commonly used industrial heat exchangers (many specialized heat exchangers are not covered in this chapter). To acquaint the reader with specific examples, major applications of most types of heat exchangers are mentioned. With a thorough understanding of this broad overview of different types of exchangers, readers will be able to apply the theory and analyses presented in the succeeding chapters to their specific needs.

REFERENCES

- ASME, 1998, *ASME Boiler and Pressure Vessel Code*, Sec. VIII, Div. 1, *Rules for Construction of Pressure Vessels*, American Society of Mechanical Engineers, New York.
- Beck, D. S., and D. G. Wilson, 1996, *Gas Turbine Regenerators*, Chapman & Hall, New York.

- Butterworth, D., 1996, Developments in shell-and-tube heat exchangers, in *New Developments in Heat Exchangers*, N. Afgan, M. Carvalho, A. Bar-Cohen, D. Butterworth, and W. Roetzel, eds., Gordon & Breach, New York, pp. 437–447.
- Kays, W. M., and A. L. London, 1998, *Compact Heat Exchangers*, reprint 3rd ed., Krieger Publishing, Malabar, FL.
- Mueller, A. C., 1973, Heat exchangers, in *Handbook of Heat Transfer*, W. M. Rohsenow and J. P. Hartnett, eds., McGraw-Hill, New York, Chapter 18.
- Reay, D. A., 1979, *Heat Recovery Systems—A Directory of Equipment and Techniques*, E. and F.N. Spon, London.
- Reay, D. A., 1999, *Learning from Experiences with Compact Heat Exchangers*, CADDET Analyses Series No. 25, Centre for the Analysis and Dissemination of Demonstrated Energy Technologies, Sittard, The Netherlands.
- Saunders, E. A. D., 1988, *Heat Exchangers: Selection, Design and Construction*, Wiley, New York.
- Shah, R. K., 1981, Classification of heat exchangers, in *Heat Exchangers: Thermal-Hydraulic Fundamentals and Design*, S. Kakaç, A. E. Bergles, and F. Mayinger, eds., Hemisphere Publishing, Washington, DC, pp. 9–46.
- Shah, R. K., 1991a, Compact heat exchanger technology and applications, in *Heat Exchanger Engineering*, Vol. 2, *Compact Heat Exchangers: Techniques for Size Reduction*, E. A. Foumeny and P. J. Heggs, eds., Ellis Horwood, London, pp. 1–29.
- Shah, R. K., 1991b, Industrial heat exchangers—functions and types, in *Industrial Heat Exchangers*, J-M. Buchlin, ed., Lecture Series No. 1991-04, von Kármán Institute for Fluid Dynamics, Belgium.
- Shah, R. K., 1994, Heat exchangers, in *Encyclopedia of Energy Technology and the Environment*, A. Bisio and S. G. Boots, eds., Wiley, New York, pp. 1651–1670.
- Shah, R. K., and W. W. Focke, 1988, Plate heat exchangers and their design theory, in *Heat Transfer Equipment Design*, R. K. Shah, E. C. Subbarao, and R. A. Mashelkar, eds., Hemisphere Publishing, Washington, DC, pp. 227–254.
- Shah, R. K., and A. D. Giovannelli, 1988, Heat pipe heat exchanger design theory, in *Heat Transfer Equipment Design*, R. K. Shah, E. C. Subbarao, and R. A. Mashelkar, eds., Hemisphere Publishing, Washington, DC, pp. 267–296.
- Shah, R. K., and A. C. Mueller, 1988, Heat exchange, in *Ullmann's Encyclopedia of Industrial Chemistry*, Unit Operations II, Vol. B3, Chapt. 2, VCH Publishers, Weinheim, Germany.
- Shah, R. K., and R. L. Webb, 1983, Compact and enhanced heat exchangers, in *Heat Exchangers: Theory and Practice*, J. Taborek, G. F. Hewitt, and N. Afgan, eds., Hemisphere/McGraw-Hill, Washington, DC, pp. 425–468.
- Suo, M., 1976, Calculation methods for performance of heat exchangers enhanced with fluidized beds, *Let. Heat Mass Transfer*, Vol. 3, pp. 555–564.
- TEMA, 1999, *Standards of TEMA*, 8th ed., Tubular Exchanger Manufacturers Association, New York.
- Walker, G., 1990, *Industrial Heat Exchangers: A Basic Guide*, 2nd ed., Hemisphere Publishing, Washington, DC.

REVIEW QUESTIONS

Where multiple choices are given, circle one or more correct answers. Explain your answers briefly.

- 1.1 Which of the following are compact heat exchangers?
- | | |
|---------------------------|---------------------------------|
| (a) double-pipe exchanger | (b) automobile radiator |
| (c) plate exchanger | (d) Stirling engine regenerator |

- 1.2 Which of the following are all prime surface heat exchangers?
 (a) steam boiler with plain tubes (b) spiral plate exchanger
 (c) automobile radiator (d) plate exchanger for beer processing
 (e) strip-fin gas turbine regenerator (f) shell-and-tube exchanger with plain tubes
- 1.3 Fins are used *primarily* to:
 (a) increase heat transfer coefficient h (b) increase surface area A
 (c) increase both h and A (d) increase neither h nor A
- 1.4 Louver fins (as compared to similar plain uncut fins) are used *primarily* to:
 (a) increase heat transfer coefficient h (b) increase surface area A
 (c) increase both h and A (d) increase neither h nor A
- 1.5 A finned double-pipe exchanger has fins on the outside of the inner tube(s) for the following reasons:
 (a) The tube outside heat transfer coefficient is high.
 (b) The tube inside heat transfer coefficient is more than double for tube outside with longitudinal flow.
 (c) Fouling is expected on the tube side.
- 1.6 Which one of the following is *not* a function fulfilled by transverse plate baffles in a shell-and-tube exchanger?
 (a) to provide counterflow operation
 (b) to support the tubes
 (c) to direct the fluid approximately at right angles to the tubes
 (d) to increase the turbulence and mixing in the shell fluid
 (e) to minimize tube-to-tube temperature differences and thermal stresses
- 1.7 Which of the following properties of plate heat exchangers, due to their specific construction features, make them particularly suited for the food processing industry?
 (a) close temperature control
 (b) easy disassembly for cleaning
 (c) low probability of one fluid to other fluid contamination
 (d) high corrosion resistance
- 1.8 In which of the following exchangers, is a single-pass crossflow arrangement used?
 (a) plate-fin exchanger (b) Ljungstrom air preheater
 (c) gasketed plate heat exchanger (d) 1–2 TEMA E shell-and-tube exchanger
 (e) double-pipe exchanger
- 1.9 *Commonly* used flow arrangements for a shell-and-tube exchanger are:
 (a) parallelflow (b) cross-counterflow (c) 1–2 parallel counterflow
- 1.10 *Commonly* used flow arrangements in a plate-fin heat exchanger are:
 (a) parallel flow (b) crossflow (c) counterflow
 (d) parallel counterflow (e) cross-counterflow (f) split flow

- 1.11** A single-coolant-tube-row car radiator is a crossflow heat exchanger with following fluid streams:
 (a) mixed–mixed (b) mixed–unmixed (c) unmixed–unmixed
- 1.12** A truck radiator with six coolant-tube rows and multilouver air centers is a cross-flow heat exchanger with following fluid streams:
 (a) mixed–mixed (b) mixed–unmixed (c) unmixed–unmixed
- 1.13** A multipass exchanger can be identified by:
 (a) inspecting the number of hot-fluid passes
 (b) inspecting the number of cold-fluid passes
 (c) trying to unfold the fluid that travels in series from one pass to the second; this unfolding results in the other fluid traveling in a series (two passes)
 (d) making sure that the number of loops (passes) is greater than one for both fluids
- 1.14** Identify which of the following are multipass heat exchangers:
 (a) over-and-under multipass arrangement with fluids unmixed between passes
 (b) side-by-side two-pass arrangement with the fluid unmixed between passes
 (c) side-by-side multipass arrangement with fluids mixed between passes
 (d) two-pass cross-parallelflow exchanger with both fluids unmixed and fluids between passes are planar (in inverted order; see Fig. 1.59*b*)
 (e) a 2–2 shell-and-tube exchanger with an F shell
 (f) a 1–2 split-flow exchanger
- 1.15** Which of the following are possible reasons for using a cross-parallelflow instead of a cross-counterflow multipass exchanger?
 (a) higher effectiveness (b) less prone to core freeze-up near the cold fluid inlet
 (c) reduced thermal stresses (d) reduced size
 (e) reduced higher axial temperature gradient in the wall
- 1.16** Fill in the blanks.
 (a) A heat exchanger is made up of heat transfer elements called _____ and fluid distribution elements called _____.
 (b) In an extended surface exchanger, the total heat transfer surface consists of _____ and _____.
 (c) A direct-transfer type exchanger is referred to simply as a _____, and a storage type exchanger is referred to simply as a _____.
 (d) Two categories of transverse baffles used for shell-and-tube exchangers are _____ baffle and _____ baffle.
 (e) Thermodynamically, the most efficient single-pass exchanger flow arrangement is _____, and the least efficient flow arrangement is _____.
- 1.17** Name the specific exchanger construction types used in the following applications:
 (a) milk pasteurizing: _____ (b) sulfuric acid cooling: _____
 (c) automotive radiator: _____ (d) blast furnace air preheating: _____
 (e) air-cooled condenser: _____

- 1.18** Circle the following statements as true or false.
- (a) T F In a well-designed heat exchanger, a significant portion of the total heat transfer takes place in inlet and outlet manifolds/tanks.
 - (b) T F Fins are generally used on the water side of an air-to-water heat exchanger.
 - (c) T F A highly compact rotary regenerator is more compact than human lungs.
 - (d) T F Free convection is more dominant than forced convection in most single-phase two-fluid heat exchangers.
 - (e) T F For highly viscous liquids, a parallelflow exchanger is desirable because the relatively high wall temperature at the inlet reduces liquid viscosity, yielding reduced flow resistance and increased heat transfer coefficient.
 - (f) T F A shell-and-tube exchanger is the most versatile exchanger.
 - (g) T F Tube-fin exchangers are generally more compact than plate-fin exchangers.
 - (h) T F A blast furnace regenerator is generally more compact than a shell-and-tube or plate heat exchanger.
 - (i) T F Figure 1.53*b* represents a single-pass heat exchanger.
 - (j) T F The heat transfer coefficient for airflow in a compact heat exchanger is higher than that for *high* water flow in a 20 mm diameter tube.
- 1.19** For the identical average inlet and outlet fluid temperatures, arrange the following exchangers in terms of decreasing largest structural temperature differences across the wall thickness direction:
- (a) parallelflow
 - (b) counterflow
 - (c) four-pass overall cross-counterflow
 - (d) two-pass overall cross-counterflow
 - (e) single-pass crossflow

Now can you tell which exchanger will have the highest thermal stresses in the dividing walls between two fluids and which will have the least thermal stresses? Why? *Hint:* Review the temperature distributions of the hot and cold fluids and of the wall.

- 1.20** Consider the flow between parallel plates (1 m width \times 1 m length) spaced 6 mm apart. Calculate the compactness (m^2/m^3) of the surface exposed to the flow between parallel plates. Now suppose that straight plain fins of 0.05 mm thickness are installed between parallel plates and spaced on 1-mm centers. Calculate the compactness for this plate-fin surface.
- 1.21** Name five heat exchangers that you are familiar with and classify them in proper subcategories of six major schemes of Fig. 1.1.